

WORKSESSION: Council Candidate Interviews

6PM

REGULAR WASECA CITY COUNCIL MEETING

TUESDAY, MAY 7 2019, 7 p.m.

AGENDA

- 1 CALL TO ORDER/ROLL CALL
- 2 MOMENT OF SILENCE/PLEDGE OF ALLEGIANCE
- 3 APPROVAL OF AGENDA
- 4 PUBLIC COMMENT

Those wishing to speak must state their name and address for the record after they reach the podium. Each person will have three (3) minutes to make his/her remarks. Speakers will address all comments to the City Council as a whole and not one individual councilmember. The Council may not take action on an item presented during the Public Comment period, unless the item is already on the agenda for action. When appropriate, the Council may refer inquiries and items brought up during the Public Comment period to the City Manager for follow up.

- 5 REQUESTS AND PRESENTATIONS
Proclamation: Small Business Week – May 5 - 11
- 6 CONSENT AGENDA
 - A. Minutes – Regular City Council Meeting/Work Session : April 16, 2019
 - B. Payroll & Expenditures
 - C. Approval of Temporary Liquor License – United Prairie Bank
 - D. Approval of Temporary Liquor License – VFW Post 1642
 - E. Approval of Contract Payments
 - F. **Resolution 19-20:** Authorize Airport Maintenance/Operations Grant Agreement
- 7 ACTION AGENDA
 - A. **Ordinance 1071:** Amending Chapter 96 & Public Hearing
 - B. Approval of Final Construction Payment: Project-2017-04
 - C. **Resolution 19-21:** Water Alliance
 - D. City Council Applicants
- 8 REPORTS
 - A. City Manager’s Report
 - B. Commission Reports
 - Fire Relief(Conrath)
 - Airport Board (Rose)
 - Park Board (Christiansen)

9 ANNOUNCEMENTS

10 ADJOURNMENT

Proclamation

MAY 5st – 11th, 2019 DECLARED AS NATIONAL SMALL BUSINESS WEEK

WHEREAS, America’s progress has been driven by pioneers who think big, take risks and work hard; and

WHEREAS, from the storefront shops that anchor Main Street to the high-tech startups that keep America on the cutting edge, small businesses are the backbone of our economy and the cornerstones of our nation’s promise; and

WHEREAS, small business owners and Main Street businesses have energy and a passion for what they do; and

WHEREAS, when we support small business, jobs are created and local communities preserve their unique culture; and

WHEREAS, because this country’s 28 million small businesses create nearly two out of three jobs in our economy, we cannot resolve ourselves to create jobs and spur economic growth in America without discussing ways to support our entrepreneurs; and

WHEREAS, the President of the United States has proclaimed National Small Business Week every year since 1963 to highlight the programs and services available to entrepreneurs through the U.S. Small Business Administration and other government agencies; and

WHEREAS, the City of Llano supports and joins in this national effort to help America’s small businesses do what they do best, create jobs, and ensure that our communities remain as vibrant tomorrow as they are today.

NOW THEREFORE, I, ROY SRP, MAYOR OF THE CITY OF WASECA, MINNESOTA do hereby, proclaim May 5th through May 11th, 2019 as National Small Business Week.

IN TESTIMONY WHEREOF, I have hereunto set my hand and caused to be affixed the Great Seal of the City of Waseca, Minnesota , this the 7th, day of May, 2019.

Mayor, Roy Srp

MINUTES
REGULAR WASECA CITY COUNCIL MEETING
TUESDAY, APRIL 16, 2019

CALL TO ORDER/ROLL CALL

1 The regular Waseca City Council meeting was called to order by Mayor Roy Srp at 7:00 p.m.

Councilmembers present: Mayor Roy Srp Daren Arndt
Mark Christiansen Allan Rose
Jeremy Conrath Les Tlougan

Staff present: Lee Mattson, City Manager
Mike Anderson, Assistant to the City Manager

Others present: Trevor Kanewischer, County Resident
Charles & Linda Cone, Residents

MOMENT OF SILENT PRAYER/PLEDGE OF ALLEGIANCE

2 A moment of silence was observed. The Pledge of Allegiance to the Flag was recited.

APPROVAL OF AGENDA

3 It was moved by Arndt, seconded by Christiansen, to approve the agenda as presented. Motion carried 6-0.

4 **PUBLIC COMMENT**
NA

5 **REQUESTS AND PRESENTATIONS**
NA

CONSENT AGENDA

6 It was moved by Tlougan, seconded by Conrath, to approve the Consent Agenda as presented. The motion carried 6-0, and included the following:

- A. Minutes – Regular City Council Meeting & Work Session – April 16, 2019
- B. Payroll & Expenditures
- C. Approval of Memorandum of Agreement – Local Union 949
- D. Appointing a Complete Count Committee – 2020 Census
- E. Approval of Master Collocation Agreement for Small Wireless Facilities

ACTION AGENDA

7A Resolution19-11: EDA Board Composition & Public Hearing

City Manager Mattson informed Council that this Resolution is amending the enabling Resolution to remove seats reserved on the Economic Development Authority for the Housing Redevelopment Authority and the Chamber of Commerce and have those seats be at large chairs. This Resolution also is clearing up all old language and creating a new document for all future reference.

Public Hearing was held at 7:06 p.m. Nobody approached the Council. The hearing closed at 7:07 p.m.

Motion was made by Conrath, seconded by Arndt to approve Resolution 19-11. Motion carried 6-0.

7B RCCA: Approving the Runway Culvert Replacement

Council was informed that this project was approved in 2018. However the scope of the work exceeded the amount in the original agreement by \$17,000 with the City portion being \$1,700 and needs Council authorization to move forward. The funds needed to cover the cost will come from the Airport Special Revenue Fund.

Motion was made by Rose, seconded by Tlougan to approve the Supplemental Authorization for City Project 2018-05. Motion carried 6-0.

7C RCCA: Park Ordinance Amendment Introduction & Set Public Hearing (May 7, 2019)

City Manager informed Council that he believes the Ordinance adopted in 2017, Council inadvertently adopted language that prohibits alcohol in most parks. The proposed amendment to Chapter 96 would allow for alcohol in parks except for City beaches, Maplewood Park (without a permit) and Tink Larson Community Field. The Public Hearing is scheduled for May 7, 2019.

Motion was made by Arndt, seconded by Conrath to set a public hearing for May 7, 2019 at 7 p.m. Motion carried 6-0.

7D Resolution 19-19: Approval of Variance for 314 2nd Ave SE

The Mayor began by thanking the Cone's for coming in to tonight's meeting. The Variance request is to allow the footprint of the house in combination with the existing accessory structure to exceed the maximum building coverage and not for impervious surface requirements of the Shoreland Ordinance. On April 9, 2019 the Planning Commission held a public hearing and recommended approval of this variance to Council with a 5-0 vote.

Motion was made by Conrath, seconded by Arndt to approve Resolution 19-19. Motion carried 6-0.

7E **RCCA: Council Applications**

The Mayor announced the two current candidates being John Clemons and Larry Johnson. After Council discussion they determined to hold a work session for interviews on Tuesday, May 7, 2019 at 6 p.m. Applications can be turned in up until 4:30 p.m. on Thursday May 2, 2019.

Motion was made by Tlougan, seconded by Christiansen to conduct Council Interviews at the May 7, 2019 work session. Motion carried 6-0.

7F **County Solar Farm Zoning Discussion**

Part of this study is to determine if there should be a specific distance of separation between existing residential properties and new solar farms. The County will also consider if there should be a prohibition on the development of solar farms within a specified distance from any city limits in Waseca County. The Planning Commission considered this issue and recommended Council support. The Council noted that the City does support the development of green energy, but noted the study period would allow the County to identify the best places for the development of that industry to occur.

Motion was made by Councilmember Tlougan to support a moratorium for 6 months or less, seconded by Srp. Motion carried 6-0.

REPORTS

8A **City Manager's Report**

- City will be undertaking some soil borings in the Birds Eye Lagoon
- Thank you to the Snow Removal Crews for their hard work
- Tink Larson Field had their season opener this past weekend
- Shelly Kolling, City Finance Directors last day is Monday
- Connecting Entrepreneurial Communities Conference Meeting was held last week. The University team walked the downtown looking for host sites

8B **Commission Reports**

Discover Waseca Tourism (Conrath)

- Summer Brochures are coming out soon
- Discussed Sinister Forest and how they are looking for volunteers
- Talked about the upcoming fair and their booth

Planning Commission (Srp, Arndt)

- The Variance for 314 2nd Ave SE was recommended for Council Approval
- Commission discussed Solar Farms and a County Moratorium study

EDA (Srp)

- Welcomed their two new members at the last meeting
- Granted Junior Achievement some grant funding
- The Fredricks talked about adding a business in the South Industrial Park

- Site Selection consultant through Jeremy Brown has been invited to the next EDA meeting
- Received a Hemp Update that things are moving along nicely
- Next meeting is May 8, 2019

Park Board (Christiansen)

- Went over Park Equipment Replacement Plan
- Clear Lake Pavilion bathrooms need some updates
- Grant information has been submitted
- Trowbridge Musical Garden will begin construction this year
- 19th Annual Park Clean Up is April 27, 2019

ANNOUNCEMENTS

9 The following miscellaneous announcements were made by Councilmembers:

Council Member Rose

- Kiesler's will be opening this month
- Docks will be installed next weekend

Council Member Christiansen

- Thank you City of Waseca Utilities for their hard work
- Burger fry for the Boy Scouts is Friday evening
- Flag retirement ceremony will be held at the fairgrounds

Council Member Arndt & Conrath

- Happy Easter

ADJOURNMENT

10 It was moved by Arndt, seconded by Conrath, to adjourn the meeting at 7:59 p.m.; motion carried 6-0.

R. D. SRP
MAYOR

MIKE ANDERSON
ASSISTANT TO THE CITY MANAGER

MINUTES
CITY COUNCIL WORK SESSION
TUESDAY, APRIL 16, 2019

The work session began at 6:00 p.m. at City Hall.

Councilmembers present: Mayor Roy Srp Daren Arndt
Mark Christiansen Allan Rose
Jeremy Conrath Les Tlougan

Staff present: Lee Mattson, City Manager
Mike Anderson, Assistant to the City Manager

CITY MANAGER GOALS

Mayor Srp opened the work session at 6 p.m.

Staff provided information that was gathered from other cities regarding their Boards & Commissions and whether they are compensated, fed lunch, or given any other benefits.

After discussion, it was determined to keep thinking of ideas of recognition for board and committee members.

There being no further discussion, the work session ended at 6:50 p.m.

R. D. SRP
MAYOR

MIKE ANDERSON
ASSISTANT TO THE CITY MANAGER



6B

LIST OF EXPENDITURES

May 7, 2019

=====

City Council	3,663.00	
Streets	28,930.43	
Parks	9,912.03	
Wastewater	10,555.87	
Utility Administration	4,419.74	
Utility Billing	7,399.97	
Electric	12,704.47	
Water	6,200.73	
Building and Code Compliance	2,449.81	
Police	57,061.81	
Administration	4,800.31	
Community Aides	770.00	
Fire	7,530.69	
Paid On Call Fire Department	605.02	
Election Judges	0.00	
PEG	0.00	
Finance	14,246.22	
Connections	3,682.85	
Community Development	5,113.85	
Engineering	15,414.52	
Recreation	2,793.56	
Econ Development	<u>2,510.96</u>	
Total Gross Payroll	200,765.84	
*Less- Payroll Deductions	<u>(68,001.06)</u>	
Net Payroll Cost		\$ 132,764.78

*These costs are included in Accounts Payable totals below

Accounts Payable

Expenditures dated:
April 12, 2019-May 2, 2019
Includes check #'s 153495-153568
Bank ACH Withdrawals..... 762,050.08

GRAND TOTAL EXPENDITURES \$ 894,814.86

Check Issue Date	Check Number	Payee	Description	Invoice GL Account	Check Amount
General Fund					
04/16/2019	153492	City of Waseca	More petty cash for TLCF Safe	101-10300-0000	50.00
Total 101103000000:					50.00
05/02/2019	153544	NeoFunds	Postage	101-15510-0000	1,000.00
Total 101155100000:					1,000.00
05/02/2019	153539	MN Sales and Use Tax Payable	Sales tax payable	101-20210-0000	275.04
Total 101202100000:					275.04
04/30/2019	41925	ACH Internal Revenue Service	FEDERAL WITHHOLDING TAX Pay Period: 4/21/2019	101-21701-0000	19,357.21 M
Total 101217010000:					19,357.21
04/30/2019	41920	MN Department of Revenue	STATE WITHHOLDING TAX Pay Period: 4/21/2019	101-21702-0000	9,057.85 M
Total 101217020000:					9,057.85
04/30/2019	41925	ACH Internal Revenue Service	SOCIAL SECURITY Pay Period: 4/21/2019	101-21703-0000	8,157.76 M
04/30/2019	41925	ACH Internal Revenue Service	SOCIAL SECURITY Pay Period: 4/21/2019	101-21703-0000	8,157.76 M
Total 101217030000:					16,315.52
04/30/2019	41922	Public Employees Retirement Assn (ACH	PERA COORD Emplr 1% Pay Period: 4/21/2019	101-21704-0000	1,284.94 M
04/30/2019	41922	Public Employees Retirement Assn (ACH	PERA COORDINATED Employee Pay Period: 4/21/2019	101-21704-0000	8,351.86 M
04/30/2019	41922	Public Employees Retirement Assn (ACH	PERA POLICE Employee Pay Period: 4/21/2019	101-21704-0000	6,729.43 M
04/30/2019	41922	Public Employees Retirement Assn (ACH	DEF CONTRIBUTION/EMPL Pay Period: 4/21/2019	101-21704-0000	88.05 M
04/30/2019	41922	Public Employees Retirement Assn (ACH	PERA COORDINATED Employer Pay Period: 4/21/2019	101-21704-0000	8,351.86 M
04/30/2019	41922	Public Employees Retirement Assn (ACH	PERA POLICE Employer Pay Period: 4/21/2019	101-21704-0000	10,094.13 M
04/30/2019	41922	Public Employees Retirement Assn (ACH	DEF CONT Employer Pay Period: 4/21/2019	101-21704-0000	88.05 M
04/30/2019	41916	U.S. Treasury	Penalty fee	101-21704-0000	769.48 M
Total 101217040000:					35,757.80
05/02/2019	20190353	Greater Mankato Area United Way	UNITED WAY Pay Period: 4/21/2019	101-21708-0000	25.00
Total 101217080000:					25.00
05/02/2019	153543	NCPERS Minnesota - 8266711	LIFE INSURANCE - PERA Pay Period: 4/21/2019	101-21711-0000	224.00
Total 101217110000:					224.00
04/30/2019	41925	ACH Internal Revenue Service	MEDICARE Pay Period: 4/21/2019	101-21712-0000	2,729.78 M
04/30/2019	41925	ACH Internal Revenue Service	MEDICARE Pay Period: 4/21/2019	101-21712-0000	2,729.78 M
Total 101217120000:					5,459.56
04/30/2019	41926	MSRS- (DEF COMP)	MSRS - ROTH (AFTER TAX) Pay Period: 4/21/2019	101-21713-0000	885.00 M
04/30/2019	41926	MSRS- (DEF COMP)	MSRS - DEF COMP Pay Period: 4/21/2019	101-21713-0000	595.00 M
Total 101217130000:					1,480.00
04/30/2019	41924	Vantagepoint Transfer Agents 457	ICMA DEF COMPENSATION Pay Period: 4/21/2019	101-21714-0000	2,065.00 M

M = Manual Check, V = Void Check

Check Issue Date	Check Number	Payee	Description	Invoice GL Account	Check Amount
Total 101217140000:					2,065.00
04/30/2019	41921	AFLAC	AFLAC AFTER TAX Pay Period: 4/7/2019	101-21715-0000	289.38 M
04/30/2019	41921	AFLAC	AFLAC PRE TAX Pay Period: 4/7/2019	101-21715-0000	677.67 M
04/30/2019	41921	AFLAC	AFLAC AFTER TAX Pay Period: 4/21/2019	101-21715-0000	289.38 M
04/30/2019	41921	AFLAC	AFLAC PRE TAX Pay Period: 4/21/2019	101-21715-0000	677.67 M
Total 101217150000:					1,934.10
04/30/2019	41915	Further	Flex/HSA Reimbursement	101-21716-0000	68.94 M
04/30/2019	41918	Further	Flex/HSA Reimbursement	101-21716-0000	206.49 M
05/02/2019	51901	Further	Flex/HSA Reimbursement	101-21716-0000	71.57 M
04/30/2019	41927	Further	HSA DEDUCTION Pay Period: 4/21/2019	101-21716-0000	632.09 M
Total 101217160000:					979.09
04/30/2019	41923	MN Child Support Payment Center	CHILD SUPPORT FLAT AMT Pay Period: 4/21/2019	101-21717-0000	1,194.73 M
Total 101217170000:					1,194.73
04/30/2019	41919	Blue Cross & Blue Shield of MN	BCBS High Ded FAMILY Pay Period: 4/7/2019	101-21720-0000	3,298.40 M
04/30/2019	41919	Blue Cross & Blue Shield of MN	BCBS High Ded FAMILY Pay Period: 4/7/2019	101-21720-0000	13,193.60 M
04/30/2019	41919	Blue Cross & Blue Shield of MN	BCBS High Ded SINGLE Pay Period: 4/7/2019	101-21720-0000	8,633.50 M
04/30/2019	41919	Blue Cross & Blue Shield of MN	BCBS 3375 Ded SINGLE Pay Period: 4/7/2019	101-21720-0000	3,437.50 M
04/30/2019	41919	Blue Cross & Blue Shield of MN	BCBS 3375 Ded FAMILY Pay Period: 4/7/2019	101-21720-0000	1,381.10 M
04/30/2019	41919	Blue Cross & Blue Shield of MN	BCBS 3375 Ded FAMILY Pay Period: 4/7/2019	101-21720-0000	5,524.40 M
04/30/2019	41919	Blue Cross & Blue Shield of MN	Cobra/disability	101-21720-0000	3,712.00 M
04/30/2019	41919	Blue Cross & Blue Shield of MN	Wellman	101-21720-0000	1,179.00 M
04/30/2019	41919	Blue Cross & Blue Shield of MN	Hellevik, B	101-21720-0000	1,973.00- M
04/30/2019	41919	Blue Cross & Blue Shield of MN	BCBS High Ded FAMILY Pay Period: 4/21/2019	101-21720-0000	3,298.40 M
04/30/2019	41919	Blue Cross & Blue Shield of MN	BCBS High Ded FAMILY Pay Period: 4/21/2019	101-21720-0000	13,193.60 M
04/30/2019	41919	Blue Cross & Blue Shield of MN	BCBS High Ded SINGLE Pay Period: 4/21/2019	101-21720-0000	8,633.50 M
04/30/2019	41919	Blue Cross & Blue Shield of MN	BCBS 3375 Ded SINGLE Pay Period: 4/21/2019	101-21720-0000	3,437.50 M
04/30/2019	41919	Blue Cross & Blue Shield of MN	BCBS 3375 Ded FAMILY Pay Period: 4/21/2019	101-21720-0000	1,381.10 M
04/30/2019	41919	Blue Cross & Blue Shield of MN	BCBS 3375 Ded FAMILY Pay Period: 4/21/2019	101-21720-0000	5,524.40 M
Total 101217200000:					73,855.00
05/02/2019	20190378	Personalized Printing Inc.	2019 Spring Newsletters	101-41110-3500	678.20
Total 101411103500:					678.20
05/02/2019	20190387	U.S. Bank - CC	Mints and nuts for Fitch Thank you	101-41110-4450	21.79
Total 101411104450:					21.79
05/02/2019	20190390	Waseca Area Senior Citizens Center	City Contribution	101-41110-4455	1,125.00
Total 101411104455:					1,125.00
05/02/2019	51902	Further	VEBA/HSA submittal May	101-41320-1310	286.50 M
05/02/2019	51902	Further	VEBA/HSA submittal May	101-41320-1310	256.59 M
Total 101413201310:					543.09

M = Manual Check, V = Void Check

Check Issue Date	Check Number	Payee	Description	Invoice GL Account	Check Amount
04/30/2019	41928	Reliance Standard	May LTD Insurance	101-41320-1340	37.98 M
04/30/2019	41928	Reliance Standard	May LTD Insurance	101-41320-1340	4.02 M
04/30/2019	41928	Reliance Standard	May LTD Insurance	101-41320-1340	11.15 M
04/30/2019	41928	Reliance Standard	May LTD Insurance	101-41320-1340	4.46 M
Total 101413201340:					57.61
05/02/2019	153561	Waseca County Public Health	Hepatitis Shot	101-41320-3000	85.00
Total 101413203000:					85.00
05/02/2019	153551	Shred-it USA LLC	Shredding service	101-41320-3100	13.83
Total 101413203100:					13.83
05/02/2019	20190387	U.S. Bank - CC	Credit for conference-Anderson	101-41320-3300	253.40-
Total 101413203300:					253.40-
05/02/2019	20190389	Waseca Area Chamber of Commerce	Employee Recognition	101-41320-4930	100.00
05/02/2019	20190389	Waseca Area Chamber of Commerce	Employee Recognition	101-41320-4930	65.00
Total 101413204930:					165.00
05/02/2019	153520	Cintas Corporation	First aid cabinet supplies	101-41320-4940	34.76
05/02/2019	153520	Cintas Corporation	First aid cabinet supplies	101-41320-4940	17.46
05/02/2019	153520	Cintas Corporation	First aid cabinet supplies	101-41320-4940	25.33
05/02/2019	153520	Cintas Corporation	First aid cabinet supplies	101-41320-4940	47.80
05/02/2019	153552	South Central College	Safety Program	101-41320-4940	1,260.00
Total 101413204940:					1,385.35
05/02/2019	20190336	A. H. Hermel Company	Pop for vending machine	101-41320-4945	11.82
Total 101413204945:					11.82
05/02/2019	51902	Further	VEBA/HSA submittal May	101-41500-1310	1,047.18 M
Total 101415001310:					1,047.18
04/30/2019	41928	Reliance Standard	May LTD Insurance	101-41500-1340	75.85 M
Total 101415001340:					75.85
04/30/2019	41917	Further	Further Admin Fees Flex HSA	101-41500-1600	212.40 M
04/30/2019	41902	Further	Flex/HSA Reimbursement	101-41500-1600	582.31 M
Total 101415001600:					794.71
05/02/2019	20190360	Innovative Office Supply	Office Supplies	101-41500-2000	43.25
Total 101415002000:					43.25
05/02/2019	20190387	U.S. Bank - CC	Dodgeballs for wellness activity	101-41500-2200	39.46
05/02/2019	20190387	U.S. Bank - CC	Credit for returned dodgeballs	101-41500-2200	128.95-

M = Manual Check, V = Void Check

Check Issue Date	Check Number	Payee	Description	Invoice GL Account	Check Amount
Total 101415002200:					89.49-
05/02/2019	153551	Shred-it USA LLC	Shredding service	101-41500-3100	64.12
Total 101415003100:					64.12
05/02/2019	20190351	Flaherty & Hood PA	March Legal Fees	101-41600-3000	1,053.75
05/02/2019	20190351	Flaherty & Hood PA	March Labor and employment consult services	101-41600-3000	218.75
05/02/2019	153562	Waseca County Treasurer	Legal Services contract payment	101-41600-3000	5,370.33
Total 101416003000:					6,642.83
05/02/2019	20190377	Pantheon Computer Systems Inc.	Computer Replacement	101-41920-2050	2,401.95
05/02/2019	20190377	Pantheon Computer Systems Inc.	Safe Case for Sara	101-41920-2050	99.99
05/02/2019	20190377	Pantheon Computer Systems Inc.	PD Server	101-41920-2050	8,499.00
Total 101419202050:					11,000.94
05/02/2019	20190377	Pantheon Computer Systems Inc.	May Service	101-41920-3100	6,277.25
Total 101419203100:					6,277.25
05/02/2019	20190377	Pantheon Computer Systems Inc.	Licenses	101-41920-4950	687.00
Total 101419204950:					687.00
05/02/2019	20190360	Innovative Office Supply	Office supplies	101-41940-2000	13.25
05/02/2019	20190360	Innovative Office Supply	Office Supplies	101-41940-2000	8.78
05/02/2019	20190360	Innovative Office Supply	Office Supplies	101-41940-2000	9.06
Total 101419402000:					31.09
05/02/2019	20190336	A. H. Hermel Company	Coffee for break room	101-41940-2170	64.77
05/02/2019	20190387	U.S. Bank - CC	Coffee creamer for city hall	101-41940-2170	12.52
Total 101419402170:					77.29
05/02/2019	20190340	Bomgaars Supply	Parts & Supplies	101-41940-2230	2.78
Total 101419402230:					2.78
05/02/2019	153546	Orkin Pest Control Inc.	Pest control-City Hall	101-41940-3100	88.85
Total 101419403100:					88.85
05/02/2019	153523	Consolidated Communications	Monthly Billing	101-41940-3200	159.97
05/02/2019	153523	Consolidated Communications	Monthly Billing	101-41940-3200	81.69
Total 101419403200:					241.66
05/02/2019	153518	Centerpoint Energy	Monthly Billing	101-41940-3800	666.43
05/02/2019	51903	City of Waseca	April Utilities	101-41940-3800	1,737.76 M
Total 101419403800:					2,404.19

M = Manual Check, V = Void Check

Check Issue Date	Check Number	Payee	Description	Invoice GL Account	Check Amount
05/02/2019	20190391	Waseca Sand & Gravel Inc.	Concrete	101-41940-4000	385.00
05/02/2019	153567	Woodridge Interiors	Tiles	101-41940-4000	167.40
Total 101419404000:					552.40
05/02/2019	51902	Further	VEBA/HSA submittal May	101-41950-1310	757.98 M
Total 101419501310:					757.98
04/30/2019	41928	Reliance Standard	May LTD Insurance	101-41950-1340	49.22 M
Total 101419501340:					49.22
05/02/2019	153528	Fame Awards	PC nameplate	101-41950-2000	21.75
05/02/2019	153528	Fame Awards	PC Nameplate	101-41950-2000	13.75
05/02/2019	20190360	Innovative Office Supply	Office Supplies	101-41950-2000	26.85
Total 101419502000:					62.35
05/02/2019	20190392	WSB & Associates Inc	March Planning Services	101-41950-3000	4,032.25
Total 101419503000:					4,032.25
05/02/2019	51902	Further	VEBA/HSA submittal May	101-42100-1310	7,044.64 M
05/02/2019	51902	Further	VEBA/HSA submittal May	101-42100-1310	323.60 M
Total 101421001310:					7,368.24
04/30/2019	41928	Reliance Standard	May LTD Insurance	101-42100-1340	461.60 M
Total 101421001340:					461.60
05/02/2019	20190360	Innovative Office Supply	Office supplies	101-42100-2000	101.57
05/02/2019	20190360	Innovative Office Supply	Office supplies	101-42100-2000	41.69
05/02/2019	20190360	Innovative Office Supply	Office supplies	101-42100-2000	6.48
05/02/2019	20190360	Innovative Office Supply	Office supplies	101-42100-2000	26.50
Total 101421002000:					176.24
05/02/2019	20190340	Bomgaars Supply	Parts & Supplies	101-42100-2170	14.99
05/02/2019	20190387	U.S. Bank - CC	Batteries for surveillance equipment	101-42100-2170	4.37
05/02/2019	20190387	U.S. Bank - CC	Evidence room supplies	101-42100-2170	50.21
05/02/2019	20190387	U.S. Bank - CC	Sanitizer and foam plates	101-42100-2170	12.21
05/02/2019	20190387	U.S. Bank - CC	Paper CD envelopes	101-42100-2170	78.13
Total 101421002170:					159.91
05/02/2019	20190345	Chrz, Jared	Uniform Allowance	101-42100-2180	32.31
05/02/2019	20190367	Markeson, Kris	Uniform Allowance	101-42100-2180	146.74
05/02/2019	20190367	Markeson, Kris	Uniform Allowance	101-42100-2180	179.47
05/02/2019	20190368	Maziarka, Chris	Uniform Allowance	101-42100-2180	241.27
05/02/2019	20190379	Streicher's	Uniforms	101-42100-2180	57.00
05/02/2019	20190379	Streicher's	bullet proof vest expense	101-42100-2180	972.50
05/02/2019	20190379	Streicher's	bullet proof vest expense	101-42100-2180	972.50
05/02/2019	20190379	Streicher's	Uniforms	101-42100-2180	67.99
05/02/2019	20190379	Streicher's	Uniforms	101-42100-2180	209.99

M = Manual Check, V = Void Check

Check Issue Date	Check Number	Payee	Description	Invoice GL Account	Check Amount
05/02/2019	20190379	Streicher's	Uniforms	101-42100-2180	128.00
05/02/2019	20190379	Streicher's	Uniforms	101-42100-2180	88.00
05/02/2019	20190379	Streicher's	Uniforms	101-42100-2180	175.00
05/02/2019	20190379	Streicher's	Uniform expense	101-42100-2180	104.00
05/02/2019	20190388	Vought, Penny	Clothing expense	101-42100-2180	445.19
Total 101421002180:					3,819.96
05/02/2019	20190383	Thornhill, Lawrence E.	Car detailing	101-42100-2220	28.00
05/02/2019	20190383	Thornhill, Lawrence E.	Vehicle Detailing	101-42100-2220	28.00
Total 101421002220:					56.00
05/02/2019	20190339	Blue Earth County	Patrol MDT's	101-42100-3100	540.00
05/02/2019	153519	Cintas Corporation	Floor Mats	101-42100-3100	15.28
05/02/2019	153519	Cintas Corporation	Floor Mats	101-42100-3100	15.28
05/02/2019	153551	Shred-it USA LLC	Shredding service	101-42100-3100	13.83
Total 101421003100:					584.39
05/02/2019	153523	Consolidated Communications	Monthly Billing	101-42100-3200	159.97
05/02/2019	153523	Consolidated Communications	Monthly Billing	101-42100-3200	256.11
05/02/2019	153523	Consolidated Communications	Monthly Billing	101-42100-3200	24.72
05/02/2019	153559	Verizon Wireless	Monthly Billing	101-42100-3200	419.90-
05/02/2019	153559	Verizon Wireless	Monthly Billing	101-42100-3200	22.45-
05/02/2019	153559	Verizon Wireless	Monthly Billing	101-42100-3200	1,316.28
05/02/2019	153559	Verizon Wireless	Monthly Billing	101-42100-3200	71.65
Total 101421003200:					1,386.38
05/02/2019	153505	88 Tactical Group	Swat Training	101-42100-3300	1,390.00
05/02/2019	20190387	U.S. Bank - CC	Meal at training	101-42100-3300	16.64
05/02/2019	20190387	U.S. Bank - CC	Gas to and from training	101-42100-3300	28.02
05/02/2019	20190387	U.S. Bank - CC	Training-Rass	101-42100-3300	310.00
05/02/2019	20190387	U.S. Bank - CC	BCA DMT recert course	101-42100-3300	75.00
05/02/2019	20190387	U.S. Bank - CC	Reg for Women Police Conference: Luiken, Hartle, Voug	101-42100-3300	550.00
05/02/2019	20190387	U.S. Bank - CC	BCA-DMT Operator Recert	101-42100-3300	75.00
05/02/2019	20190387	U.S. Bank - CC	Fuel to get to training	101-42100-3300	27.60
05/02/2019	20190387	U.S. Bank - CC	Fuel to get home from training	101-42100-3300	23.81
05/02/2019	20190387	U.S. Bank - CC	Meal at MN Cheifs Police Assoc Conference	101-42100-3300	8.79
05/02/2019	20190387	U.S. Bank - CC	Meal at MN Cheifs Police Assoc Conference	101-42100-3300	34.79
05/02/2019	20190387	U.S. Bank - CC	Meal at MN Cheifs Police Assoc Conference	101-42100-3300	9.17
05/02/2019	20190387	U.S. Bank - CC	Meal at MN Cheifs Police Assoc Conference	101-42100-3300	34.19
05/02/2019	20190387	U.S. Bank - CC	Room at MN Cheifs Police Assoc Conference	101-42100-3300	368.28
05/02/2019	20190387	U.S. Bank - CC	Meal at MN Cheifs Police Assoc Conference	101-42100-3300	10.74
05/02/2019	20190387	U.S. Bank - CC	Meal at MN Cheifs Police Assoc Conference	101-42100-3300	16.57
05/02/2019	20190387	U.S. Bank - CC	Lodging while at MN Cheifs Police Assoc Conference	101-42100-3300	368.28
Total 101421003300:					3,346.88
05/02/2019	20190378	Personalized Printing Inc.	printing expense	101-42100-3500	170.80
Total 101421003500:					170.80
05/02/2019	51903	City of Waseca	April Utilities	101-42100-3800	832.54 M

M = Manual Check, V = Void Check

Check Issue Date	Check Number	Payee	Description	Invoice GL Account	Check Amount
Total 101421003800:					832.54
05/02/2019	153563	Waseca Rotary Club	1st Qtr Rotary dues	101-42100-4330	185.00
Total 101421004330:					185.00
05/02/2019	153508	Ahlman's	Swat Team Rifle	101-42100-4370	1,344.98
05/02/2019	153525	Defender Depot LLC	Swat Expense	101-42100-4370	2,796.62
05/02/2019	20190379	Streicher's	swat expense	101-42100-4370	55.00
05/02/2019	20190387	U.S. Bank - CC	Streamlite mount	101-42100-4370	109.86
05/02/2019	20190387	U.S. Bank - CC	Swat rifle accessories	101-42100-4370	52.00
05/02/2019	20190387	U.S. Bank - CC	Swat rifle accessories	101-42100-4370	22.71
Total 101421004370:					4,381.17
05/02/2019	153522	City of Waseca	compliance check case	101-42100-4640	100.00
Total 101421004640:					100.00
05/02/2019	51902	Further	VEBA/HSA submittal May	101-42200-1310	1,380.86 M
Total 101422001310:					1,380.86
04/30/2019	41928	Reliance Standard	May LTD Insurance	101-42200-1340	56.97 M
Total 101422001340:					56.97
05/02/2019	20190340	Bomgaars Supply	Parts & Supplies	101-42200-2170	12.75
Total 101422002170:					12.75
05/02/2019	153510	Aspen Mills Inc	class a uniform	101-42200-2180	539.30
05/02/2019	153510	Aspen Mills Inc	class a uniform	101-42200-2180	513.10
05/02/2019	153510	Aspen Mills Inc	class a uniform - Kahnke	101-42200-2180	509.60
Total 101422002180:					1,562.00
05/02/2019	153542	My-Lor Inc	Helmet Tags	101-42200-2190	20.76
Total 101422002190:					20.76
05/02/2019	153519	Cintas Corporation	Floor Mats	101-42200-3100	15.29
05/02/2019	153519	Cintas Corporation	Floor Mats	101-42200-3100	15.29
Total 101422003100:					30.58
05/02/2019	153523	Consolidated Communications	Monthly Billing	101-42200-3200	24.73
05/02/2019	153559	Verizon Wireless	Monthly Billing	101-42200-3200	26.97-
05/02/2019	153559	Verizon Wireless	Monthly Billing	101-42200-3200	210.19
Total 101422003200:					207.95
05/02/2019	51903	City of Waseca	April Utilities	101-42200-3800	832.53 M
05/02/2019	51903	City of Waseca	April Utilities	101-42200-3800	38.87 M
05/02/2019	153523	Consolidated Communications	Monthly Billing	101-42200-3800	26.48

M = Manual Check, V = Void Check

Check Issue Date	Check Number	Payee	Description	Invoice GL Account	Check Amount
Total 101422003800:					897.88
05/02/2019	51902	Further	VEBA/HSA submittal May	101-42400-1310	513.18 M
05/02/2019	51902	Further	VEBA/HSA submittal May	101-42400-1310	116.99 M
Total 101424001310:					630.17
04/30/2019	41928	Reliance Standard	May LTD Insurance	101-42400-1340	21.47 M
04/30/2019	41928	Reliance Standard	May LTD Insurance	101-42400-1340	6.76 M
Total 101424001340:					28.23
05/02/2019	20190387	U.S. Bank - CC	Desk drawer stationary holder	101-42400-2000	84.22
Total 101424002000:					84.22
05/02/2019	20190346	City Building Inspection Services LLC	building inpections	101-42400-3000	25.55
05/02/2019	20190346	City Building Inspection Services LLC	building inpections	101-42400-3000	4,669.32
Total 101424003000:					4,694.87
05/02/2019	153559	Verizon Wireless	Monthly Billing	101-42400-3200	13.65-
05/02/2019	153559	Verizon Wireless	Monthly Billing	101-42400-3200	42.00
Total 101424003200:					28.35
05/02/2019	51902	Further	VEBA/HSA submittal May	101-43000-1310	120.53 M
05/02/2019	51902	Further	VEBA/HSA submittal May	101-43000-1310	1,116.44 M
Total 101430001310:					1,236.97
04/30/2019	41928	Reliance Standard	May LTD Insurance	101-43000-1340	6.97 M
04/30/2019	41928	Reliance Standard	May LTD Insurance	101-43000-1340	98.07 M
Total 101430001340:					105.04
05/02/2019	20190360	Innovative Office Supply	Office Supplies	101-43000-2000	7.60
Total 101430002000:					7.60
05/02/2019	20190343	Cady Business Technologies Inc	Monthly Phone Support Plan	101-43000-3200	262.62
05/02/2019	153559	Verizon Wireless	Monthly Billing	101-43000-3200	72.79
05/02/2019	153559	Verizon Wireless	Monthly Billing	101-43000-3200	22.45-
05/02/2019	153559	Verizon Wireless	Monthly Billing	101-43000-3200	22.45-
05/02/2019	153559	Verizon Wireless	Monthly Billing	101-43000-3200	71.65
05/02/2019	153559	Verizon Wireless	Monthly Billing	101-43000-3200	71.65
Total 101430003200:					433.81
05/02/2019	51902	Further	VEBA/HSA submittal May	101-43100-1310	1,943.21 M
05/02/2019	51902	Further	VEBA/HSA submittal May	101-43100-1310	33.91 M
Total 101431001310:					1,977.12
04/30/2019	41928	Reliance Standard	May LTD Insurance	101-43100-1340	98.34 M

M = Manual Check, V = Void Check

Check Issue Date	Check Number	Payee	Description	Invoice GL Account	Check Amount	
04/30/2019	41928	Reliance Standard	May LTD Insurance	101-43100-1340	1.95	M
Total 101431001340:					100.29	
05/02/2019	20190340	Bomgaars Supply	Parts & Supplies	101-43100-2170	82.32	
05/02/2019	153517	CCP Industries Inc.	supplies	101-43100-2170	231.84	
05/02/2019	20190357	Holtmeier Construction Inc.	crushed rock	101-43100-2170	411.76	
05/02/2019	20190361	James Brothers Construction Inc.	Gravel	101-43100-2170	336.00	
05/02/2019	20190387	U.S. Bank - CC	Class 2 T-shirts	101-43100-2170	1,552.05	
05/02/2019	153558	USA Blue Book	water truck couplers	101-43100-2170	176.42	
Total 101431002170:					2,790.39	
05/02/2019	153521	City of Saint Paul	Hot Mix	101-43100-2171	1,242.40	
Total 101431002171:					1,242.40	
05/02/2019	20190337	AmeriPride Services Inc	uniform-service	101-43100-2180	169.20	
05/02/2019	20190337	AmeriPride Services Inc	uniform-service	101-43100-2180	169.20	
05/02/2019	20190337	AmeriPride Services Inc	uniform-service	101-43100-2180	175.70	
Total 101431002180:					514.10	
05/02/2019	20190340	Bomgaars Supply	Parts & Supplies	101-43100-2400	115.10	
Total 101431002400:					115.10	
05/02/2019	153523	Consolidated Communications	Monthly Billing	101-43100-3200	26.48	
Total 101431003200:					26.48	
05/02/2019	153518	Centerpoint Energy	Monthly Billing	101-43100-3800	1,117.40	
05/02/2019	51903	City of Waseca	April Utilities	101-43100-3800	38.87	M
05/02/2019	51903	City of Waseca	April Utilities	101-43100-3800	915.57	M
Total 101431003800:					2,071.84	
05/02/2019	51902	Further	VEBA/HSA submittal May	101-43125-1310	503.80	M
05/02/2019	51902	Further	VEBA/HSA submittal May	101-43125-1310	33.91	M
Total 101431251310:					537.71	
04/30/2019	41928	Reliance Standard	May LTD Insurance	101-43125-1340	25.50	M
04/30/2019	41928	Reliance Standard	May LTD Insurance	101-43125-1340	1.95	M
Total 101431251340:					27.45	
05/02/2019	20190354	H & J Fuel Inc	dyed fuel	101-43125-2120	1,257.00	
Total 101431252120:					1,257.00	
04/17/2019	153441	Cargill Inc. - Salt Division	Road salt	101-43125-2170	2,592.36-	V
05/02/2019	153516	Cargill Inc. - Salt Division	Road salt	101-43125-2170	87.18	
Total 101431252170:					2,505.18-	

M = Manual Check, V = Void Check

Check Issue Date	Check Number	Payee	Description	Invoice GL Account	Check Amount
05/02/2019	153506	Affordable Lawn Care Inc	2019 Snow hauling	101-43125-3100	1,567.50
05/02/2019	20190361	James Brothers Construction Inc.	2019 snow hauling	101-43125-3100	2,040.00
Total 101431253100:					3,607.50
05/02/2019	51902	Further	VEBA/HSA submittal May	101-43170-1310	107.96 M
Total 101431701310:					107.96
04/30/2019	41928	Reliance Standard	May LTD Insurance	101-43170-1340	5.46 M
Total 101431701340:					5.46
05/02/2019	51903	City of Waseca	April Utilities	101-43170-3800	189.53 M
Total 101431703800:					189.53
05/02/2019	51902	Further	VEBA/HSA submittal May	101-43220-1310	179.93 M
Total 101432201310:					179.93
04/30/2019	41928	Reliance Standard	May LTD Insurance	101-43220-1340	9.11 M
Total 101432201340:					9.11
05/02/2019	20190387	U.S. Bank - CC	Safe for concessions @ TLCF	101-45100-2170	89.98
Total 101451002170:					89.98
05/02/2019	20190359	Independent School District #829	City Contribution Comm Ed	101-45100-3100	8,333.33
Total 101451003100:					8,333.33
05/02/2019	153523	Consolidated Communications	Monthly Billing	101-45100-3200	22.98
Total 101451003200:					22.98
05/02/2019	153535	LeSueur-Waseca Public Health Services	Category 2	101-45100-4500	245.00
Total 101451004500:					245.00
05/02/2019	51902	Further	VEBA/HSA submittal May	101-45130-1310	283.60 M
Total 101451301310:					283.60
05/02/2019	20190387	U.S. Bank - CC	Scheduling App for recreation staff	101-45130-2000	198.00
05/02/2019	20190387	U.S. Bank - CC	Commercial pool & Spa book	101-45130-2000	39.90
Total 101451302000:					237.90
05/02/2019	153523	Consolidated Communications	Monthly Billing	101-45130-3200	156.36
Total 101451303200:					156.36
05/02/2019	20190387	U.S. Bank - CC	how to grow our brand through social media conference	101-45130-3300	99.00

M = Manual Check, V = Void Check

Check Issue Date	Check Number	Payee	Description	Invoice GL Account	Check Amount
Total 101451303300:					99.00
05/02/2019	51903	City of Waseca	April Utilities	101-45130-3800	494.05 M
Total 101451303800:					494.05
05/02/2019	153536	Mankato Tent & Awning Co.	Umbrella Repair	101-45130-4000	340.00
Total 101451304000:					340.00
05/02/2019	20190387	U.S. Bank - CC	Boiler License renewal	101-45130-4330	20.00
Total 101451304330:					20.00
05/02/2019	153535	LeSueur-Waseca Public Health Services	2019 license food, pool and lodging base fee	101-45130-4500	165.00
05/02/2019	153535	LeSueur-Waseca Public Health Services	Swimming pool	101-45130-4500	355.00
Total 101451304500:					520.00
05/02/2019	51902	Further	VEBA/HSA submittal May	101-45200-1310	1,282.00 M
05/02/2019	51902	Further	VEBA/HSA submittal May	101-45200-1310	70.90 M
Total 101452001310:					1,352.90
04/30/2019	41928	Reliance Standard	May LTD Insurance	101-45200-1340	81.97 M
04/30/2019	41928	Reliance Standard	May LTD Insurance	101-45200-1340	17.85 M
Total 101452001340:					99.82
05/02/2019	20190340	Bomgaars Supply	Parts & Supplies	101-45200-2170	53.93
05/02/2019	153527	DH Athletics LLC	Base pegs	101-45200-2170	73.00
05/02/2019	20190387	U.S. Bank - CC	Planter pots for TLCF	101-45200-2170	184.00
Total 101452002170:					310.93
05/02/2019	20190376	Owatonna Shoe Company	Safety boots - Rick T	101-45200-2190	145.00
Total 101452002190:					145.00
05/02/2019	20190372	MTI Distributing Inc.	Toro mower spindle assembly	101-45200-2210	321.27
Total 101452002210:					321.27
05/02/2019	20190340	Bomgaars Supply	Parts & Supplies	101-45200-2280	121.96
05/02/2019	20190387	U.S. Bank - CC	Supplies	101-45200-2280	91.12
05/02/2019	153566	Winegar, Dave	Canopy for TLCF	101-45200-2280	55.00
Total 101452002280:					268.08
05/02/2019	153512	Auto Value Waseca	Parts	101-45200-2400	161.99
05/02/2019	20190340	Bomgaars Supply	Parts & Supplies	101-45200-2400	288.94
05/02/2019	20190387	U.S. Bank - CC	Poly Fence cap tool TLCF	101-45200-2400	70.03
Total 101452002400:					520.96

M = Manual Check, V = Void Check

Check Issue Date	Check Number	Payee	Description	Invoice GL Account	Check Amount
05/02/2019	153537	Mediacom	TLCF	101-45200-3200	140.26
Total 101452003200:					140.26
05/02/2019	153518	Centerpoint Energy	Monthly Billing	101-45200-3800	360.72
05/02/2019	153518	Centerpoint Energy	Monthly Billing	101-45200-3800	51.15
05/02/2019	51903	City of Waseca	April Utilities	101-45200-3800	385.92 M
Total 101452003800:					797.79
05/02/2019	20190344	Christensen Tire Service	Tire repair	101-45200-4040	21.22
Total 101452004040:					21.22
05/02/2019	51903	City of Waseca	April Utilities	101-45500-3800	763.82 M
05/02/2019	153523	Consolidated Communications	Monthly Billing	101-45500-3800	47.99
05/02/2019	153523	Consolidated Communications	Monthly Billing	101-45500-3800	3.51
Total 101455003800:					815.32
05/02/2019	153560	Waseca County Auditor-Treasurer	1st half 2019 property tax	101-49210-4992	734.57
Total 101492104992:					734.57
Total General Fund:					270,779.52
Airport					
05/02/2019	20190351	Flaherty & Hood PA	March Legal Fees	230-49810-3000	145.00
05/02/2019	20190385	Toltz King Duvall Anderson & Assoc Inc.	Airport Zoning Ordinance Update	230-49810-3000	1,830.00
Total 230498103000:					1,975.00
05/02/2019	153556	Stensrud Aviation	Airport contract payment	230-49810-3100	2,300.00
Total 230498103100:					2,300.00
05/02/2019	51904	CenturyLink	Airport service	230-49810-3200	103.98 M
Total 230498103200:					103.98
05/02/2019	153518	Centerpoint Energy	Monthly Billing	230-49810-3800	41.37
05/02/2019	51903	City of Waseca	April Utilities	230-49810-3800	61.50 M
05/02/2019	153568	Xcel Energy	March Service	230-49810-3800	248.05
05/02/2019	153568	Xcel Energy	March Service	230-49810-3800	90.50
Total 230498103800:					441.42
05/02/2019	20190371	MN Pollution Control Agency	MPCA ISW PERMIT	230-49810-4500	400.00
Total 230498104500:					400.00
05/02/2019	153560	Waseca County Auditor-Treasurer	1st half 2019 property tax	230-49810-4800	56.00
05/02/2019	153560	Waseca County Auditor-Treasurer	1st half 2019 property tax	230-49810-4800	7,501.00
05/02/2019	153560	Waseca County Auditor-Treasurer	1st half 2019 property tax	230-49810-4800	1,801.00

M = Manual Check, V = Void Check

Check Issue Date	Check Number	Payee	Description	Invoice GL Account	Check Amount
Total 230498104800:					9,358.00
05/02/2019	20190385	Toltz King Duvall Anderson & Assoc Inc.	A/E Services FBO Hangar	230-49810-5200	328.92
Total 230498105200:					328.92
Total Airport:					14,907.32
Economic Development-General f					
05/02/2019	51902	Further	VEBA/HSA submittal May	261-46700-1310	256.59 M
Total 261467001310:					256.59
04/30/2019	41928	Reliance Standard	May LTD Insurance	261-46700-1340	11.16 M
Total 261467001340:					11.16
05/02/2019	20190351	Flaherty & Hood PA	March Legal Fees	261-46700-3000	873.75
Total 261467003000:					873.75
05/02/2019	153530	Greater Mankato Growth Inc	Table Sponsorship	261-46700-3300	700.00
05/02/2019	20190387	U.S. Bank - CC	CEC Conference planners lunch	261-46700-3300	67.68
Total 261467003300:					767.68
05/02/2019	20190389	Waseca Area Chamber of Commerce	Activity sponsorship	261-46700-4330	75.00
Total 261467004330:					75.00
Total Economic Development-General f:					1,984.18
Police Reserve					
05/02/2019	20190379	Streicher's	Police Reserve Expense	275-49212-2180	296.98
Total 275492122180:					296.98
Total Police Reserve:					296.98
Safe Haven Grant					
05/02/2019	51902	Further	VEBA/HSA submittal May	279-46350-1310	610.10 M
Total 279463501310:					610.10
04/30/2019	41928	Reliance Standard	May LTD Insurance	279-46350-1340	31.09 M
Total 279463501340:					31.09
05/02/2019	153559	Verizon Wireless	Monthly Billing	279-46350-3200	22.45-
05/02/2019	153559	Verizon Wireless	Monthly Billing	279-46350-3200	71.65
Total 279463503200:					49.20
Total Safe Haven Grant:					690.39

M = Manual Check, V = Void Check

Check Issue Date	Check Number	Payee	Description	Invoice GL Account	Check Amount
Capital Improvement					
05/02/2019	20190342	Britton Plumbing & Heating LLC	Tink Plumbing Pay App #1	430-43010-5340	2,885.25
05/02/2019	153524	Construction Supply Inc	Tink Larson Community Field Payment	430-43010-5340	397.65
05/02/2019	20190364	Koronis Fabricating Inc	Tink Larson Community Field Payment	430-43010-5340	14,457.50
05/02/2019	20190369	Merit Contracting Inc	Tink Larson Field Payment	430-43010-5340	8,129.86
05/02/2019	153565	Widseth Smith Nolting & Assoc Inc	Construction Administration	430-43010-5340	2,362.00
05/02/2019	153565	Widseth Smith Nolting & Assoc Inc	Deduct	430-43010-5340	1,240.00-
Total 430430105340:					26,992.26
05/02/2019	20190373	Nielsen Concrete LLC	2017-04 Payment Four-Final	430-43010-5460	2,505.76
Total 430430105460:					2,505.76
05/02/2019	20190349	Dirt Merchant Inc	Partial Payment No. 5 2018-01 Project	430-43010-5560	3,463.26
05/02/2019	20190349	Dirt Merchant Inc	Partial Payment No. 6	430-43010-5560	28,137.86
05/02/2019	20190392	WSB & Associates Inc	3rd St NE Engineering Services	430-43010-5560	749.00
05/02/2019	20190392	WSB & Associates Inc	3rd St NE Dept of Health Permit	430-43010-5560	150.00
Total 430430105560:					32,500.12
Total Capital Improvement:					61,998.14
Annexation & Growth fund					
05/02/2019	153560	Waseca County Auditor-Treasurer	1st half 2019 property tax	470-46800-4800	1,590.00
05/02/2019	153560	Waseca County Auditor-Treasurer	1st half 2019 property insurance	470-46800-4800	710.00
Total 470468004800:					2,300.00
Total Annexation & Growth fund:					2,300.00
Water					
05/02/2019	153539	MN Sales and Use Tax Payable	Sales tax payable	601-20210-0000	985.32
Total 601202100000:					985.32
05/02/2019	153531	Hawkins Inc	City Wells Chemicals	601-49401-2170	7,975.66
Total 601494012170:					7,975.66
05/02/2019	20190340	Bomgaars Supply	Parts & Supplies	601-49401-2230	2.39
Total 601494012230:					2.39
05/02/2019	51903	City of Waseca	April Utilities	601-49401-3800	7,433.53 M
Total 601494013800:					7,433.53
05/02/2019	51902	Further	VEBA/HSA submittal May	601-49430-1310	354.50 M
05/02/2019	51902	Further	VEBA/HSA submittal May	601-49430-1310	1,762.18 M
Total 601494301310:					2,116.68
04/30/2019	41928	Reliance Standard	May LTD Insurance	601-49430-1340	24.46 M
04/30/2019	41928	Reliance Standard	May LTD Insurance	601-49430-1340	24.88 M

M = Manual Check, V = Void Check

Check Issue Date	Check Number	Payee	Description	Invoice GL Account	Check Amount
Total 601494301340:					49.34
05/02/2019	20190337	AmeriPride Services Inc	uniform service	601-49430-2180	10.00
05/02/2019	20190337	AmeriPride Services Inc	uniform service	601-49430-2180	10.00
Total 601494302180:					20.00
05/02/2019	20190375	Northern Safety Co. Inc.	Safety Eye Wear	601-49430-2190	55.34
Total 601494302190:					55.34
05/02/2019	20190370	Metering & Technology Solutions	Meter	601-49430-2215	6,985.92
Total 601494302215:					6,985.92
05/02/2019	20190348	Core & Main LP	Main Supplies	601-49430-2230	1,390.00
05/02/2019	20190348	Core & Main LP	Main Supplies	601-49430-2230	1,731.04
05/02/2019	153549	Rhino - A Divison of RepNet Inc.	Locate Supplies	601-49430-2230	219.75
05/02/2019	20190391	Waseca Sand & Gravel Inc.	Water Main Repair	601-49430-2230	1,122.00
Total 601494302230:					4,462.79
05/02/2019	20190365	Lenz Lawn Care & Landscaping Inc.	Third Street Project	601-49430-3100	100.00
05/02/2019	20190384	Timm's Trucking Inc.	CUrb stop repair	601-49430-3100	617.50
05/02/2019	20190384	Timm's Trucking Inc.	Curb stop repair	601-49430-3100	1,286.35
05/02/2019	20190384	Timm's Trucking Inc.	Curb stop repair	601-49430-3100	75.00
Total 601494303100:					2,078.85
05/02/2019	153559	Verizon Wireless	Monthly Billing	601-49430-3200	18.06-
05/02/2019	153559	Verizon Wireless	Monthly Billing	601-49430-3200	68.39
Total 601494303200:					50.33
05/02/2019	51902	Further	VEBA/HSA submittal May	601-49585-1310	107.77 M
05/02/2019	51902	Further	VEBA/HSA submittal May	601-49585-1310	314.58 M
Total 601495851310:					422.35
04/30/2019	41928	Reliance Standard	May LTD Insurance	601-49585-1340	20.56 M
Total 601495851340:					20.56
05/02/2019	20190360	Innovative Office Supply	Office Supplies	601-49585-2000	6.03
05/02/2019	20190387	U.S. Bank - CC	Replacement parts for phone headsets	601-49585-2000	49.95
05/02/2019	20190387	U.S. Bank - CC	Replacement parts for phone headsets	601-49585-2000	4.65
Total 601495852000:					60.63
05/02/2019	153523	Consolidated Communications	Monthly Billing	601-49585-3200	42.66
05/02/2019	153557	U.S. Postal Service	Postage - May utility bills	601-49585-3200	430.50
Total 601495853200:					473.16
05/02/2019	51902	Further	VEBA/HSA submittal May	601-49586-1310	34.38 M

M = Manual Check, V = Void Check

Check Issue Date	Check Number	Payee	Description	Invoice GL Account	Check Amount	
05/02/2019	51902	Further	VEBA/HSA submittal May	601-49586-1310	171.06	M
Total 601495861310:					205.44	
04/30/2019	41928	Reliance Standard	May LTD Insurance	601-49586-1340	4.02	M
04/30/2019	41928	Reliance Standard	May LTD Insurance	601-49586-1340	2.58	M
04/30/2019	41928	Reliance Standard	May LTD Insurance	601-49586-1340	12.96	M
Total 601495861340:					19.56	
05/02/2019	153551	Shred-it USA LLC	Shredding service	601-49586-3100	64.13	
Total 601495863100:					64.13	
05/02/2019	20190387	U.S. Bank - CC	Meal at Training	601-49586-3300	15.43	
05/02/2019	20190387	U.S. Bank - CC	Room while at Training	601-49586-3300	91.41	
Total 601495863300:					106.84	
05/02/2019	20190377	Pantheon Computer Systems Inc.	May Service	601-49586-4950	896.75	
Total 601495864950:					896.75	
05/02/2019	20190348	Core & Main LP	Valve Project	601-49593-5300	2,939.31	
05/02/2019	153533	Keys Well Drilling Company	Well Project	601-49593-5300	26,315.00	
Total 601495935300:					29,254.31	
05/02/2019	153554	Stantec Consulting Services Inc	Well Project	601-49593-5400	3,686.50	
Total 601495935400:					3,686.50	
Total Water:					67,426.38	
Sanitary Sewer						
05/02/2019	51902	Further	VEBA/HSA submittal May	602-49470-1310	647.73	M
05/02/2019	51902	Further	VEBA/HSA submittal May	602-49470-1310	33.91	M
Total 602494701310:					681.64	
04/30/2019	41928	Reliance Standard	May LTD Insurance	602-49470-1340	32.78	M
04/30/2019	41928	Reliance Standard	May LTD Insurance	602-49470-1340	1.95	M
Total 602494701340:					34.73	
05/02/2019	153523	Consolidated Communications	Monthly Billing	602-49470-3200	411.69	
05/02/2019	153559	Verizon Wireless	Monthly Billing	602-49470-3200	18.06-	
05/02/2019	153559	Verizon Wireless	Monthly Billing	602-49470-3200	18.06-	
05/02/2019	153559	Verizon Wireless	Monthly Billing	602-49470-3200	68.39	
05/02/2019	153559	Verizon Wireless	Monthly Billing	602-49470-3200	68.39	
Total 602494703200:					512.35	
05/02/2019	20190387	U.S. Bank - CC	Meal while at training	602-49470-3300	24.71	
05/02/2019	20190387	U.S. Bank - CC	Meal while at training	602-49470-3300	29.78	
05/02/2019	20190387	U.S. Bank - CC	Hotel for conference	602-49470-3300	329.36	

M = Manual Check, V = Void Check

Check Issue Date	Check Number	Payee	Description	Invoice GL Account	Check Amount
05/02/2019	20190387	U.S. Bank - CC	Hotel for conference	602-49470-3300	329.36
Total 602494703300:					713.21
05/02/2019	153518	Centerpoint Energy	Monthly Billing	602-49470-3800	119.22
05/02/2019	51903	City of Waseca	April Utilities	602-49470-3800	2,205.30 M
Total 602494703800:					2,324.52
05/02/2019	20190347	Continental Research Corporation	lift station cleaner	602-49470-4020	815.25
05/02/2019	153541	Momar Inc	lift station degreaser	602-49470-4020	1,253.56
05/02/2019	153545	Olsen Chain & Cable Inc	stainless parts for basket	602-49470-4020	212.86
Total 602494704020:					2,281.67
05/02/2019	51902	Further	VEBA/HSA submittal May	602-49480-1310	265.88 M
Total 602494801310:					265.88
04/30/2019	41928	Reliance Standard	May LTD Insurance	602-49480-1340	73.38 M
Total 602494801340:					73.38
05/02/2019	20190354	H & J Fuel Inc	Generator fuel	602-49480-2120	1,174.44
Total 602494802120:					1,174.44
05/02/2019	20190340	Bomgaars Supply	Parts & Supplies	602-49480-2170	33.93
05/02/2019	153531	Hawkins Inc	Alum	602-49480-2170	5,404.90
05/02/2019	153531	Hawkins Inc	Chlorine Sulfur Dioxide	602-49480-2170	2,314.00
05/02/2019	153548	Red Feather Paper Company	Janitor Supplies	602-49480-2170	26.00
05/02/2019	20190387	U.S. Bank - CC	Lab supplies	602-49480-2170	11.30
05/02/2019	20190387	U.S. Bank - CC	Lab supplies	602-49480-2170	126.50
05/02/2019	20190387	U.S. Bank - CC	Keys for plant	602-49480-2170	7.88
05/02/2019	20190387	U.S. Bank - CC	Food for workers couldn't leave due to high flow	602-49480-2170	17.28
05/02/2019	153558	USA Blue Book	Supplies	602-49480-2170	164.98
Total 602494802170:					8,106.77
05/02/2019	20190340	Bomgaars Supply	Parts & Supplies	602-49480-2180	158.93
Total 602494802180:					158.93
05/02/2019	20190362	John Henry Foster Minnesota Inc.	Compressor parts	602-49480-2210	163.12
Total 602494802210:					163.12
05/02/2019	20190366	M & R Electric Inc.	Electrician	602-49480-3100	434.60
05/02/2019	20190374	North Shore Analytical Inc.	Permit Testing	602-49480-3100	570.00
05/02/2019	153553	Spee-Dee Delivery Service Inc.	Speedee Shipping	602-49480-3100	42.06
Total 602494803100:					1,046.66
05/02/2019	153523	Consolidated Communications	Monthly Billing	602-49480-3200	145.42
05/02/2019	153559	Verizon Wireless	Monthly Billing	602-49480-3200	22.45-
05/02/2019	153559	Verizon Wireless	Monthly Billing	602-49480-3200	71.65

M = Manual Check, V = Void Check

Check Issue Date	Check Number	Payee	Description	Invoice GL Account	Check Amount
Total 602494803200:					194.62
05/02/2019	20190387	U.S. Bank - CC	Room for Schmidt at training	602-49480-3300	494.04
Total 602494803300:					494.04
05/02/2019	153518	Centerpoint Energy	Monthly Billing	602-49480-3800	2,214.17
05/02/2019	51903	City of Waseca	April Utilities	602-49480-3800	558.18 M
05/02/2019	153568	Xcel Energy	March Service	602-49480-3800	11,435.54
Total 602494803800:					14,207.89
05/02/2019	20190371	MN Pollution Control Agency	Permit Application Fee	602-49480-4500	5,900.00
Total 602494804500:					5,900.00
05/02/2019	153520	Cintas Corporation	WWTP First Aid Cabinet Supplies	602-49480-4940	58.40
Total 602494804940:					58.40
05/02/2019	51902	Further	VEBA/HSA submittal May	602-49585-1310	107.77 M
05/02/2019	51902	Further	VEBA/HSA submittal May	602-49585-1310	314.58 M
Total 602495851310:					422.35
04/30/2019	41928	Reliance Standard	May LTD Insurance	602-49585-1340	20.56 M
Total 602495851340:					20.56
05/02/2019	20190360	Innovative Office Supply	Office Supplies	602-49585-2000	6.03
05/02/2019	20190387	U.S. Bank - CC	Replacement parts for phone headsets	602-49585-2000	49.95
05/02/2019	20190387	U.S. Bank - CC	Replacement parts for phone headsets	602-49585-2000	4.65
Total 602495852000:					60.63
05/02/2019	153523	Consolidated Communications	Monthly Billing	602-49585-3200	42.66
05/02/2019	153557	U.S. Postal Service	Postage - May utility bills	602-49585-3200	430.49
Total 602495853200:					473.15
05/02/2019	51902	Further	VEBA/HSA submittal May	602-49586-1310	34.38 M
05/02/2019	51902	Further	VEBA/HSA submittal May	602-49586-1310	171.06 M
Total 602495861310:					205.44
04/30/2019	41928	Reliance Standard	May LTD Insurance	602-49586-1340	4.02 M
04/30/2019	41928	Reliance Standard	May LTD Insurance	602-49586-1340	2.58 M
04/30/2019	41928	Reliance Standard	May LTD Insurance	602-49586-1340	12.96 M
Total 602495861340:					19.56
05/02/2019	153551	Shred-it USA LLC	Shredding service	602-49586-3100	64.13
Total 602495863100:					64.13

M = Manual Check, V = Void Check

Check Issue Date	Check Number	Payee	Description	Invoice GL Account	Check Amount
05/02/2019	153560	Waseca County Auditor-Treasurer	2019 property tax	602-49586-4800	99.01
Total 602495864800:					99.01
05/02/2019	20190377	Pantheon Computer Systems Inc.	May Service	602-49586-4950	896.75
Total 602495864950:					896.75
05/02/2019	153513	Automatic Systems Company	Lift Station SCADA Additions	602-49593-5300	42,508.00
05/02/2019	153513	Automatic Systems Company	Lift Station SCADA Additions	602-49593-5300	58,736.00
05/02/2019	153554	Stantec Consulting Services Inc	Micro Monitoring	602-49593-5300	1,055.50
Total 602495935300:					102,299.50
Total Sanitary Sewer:					142,953.33
Electric Utility					
05/02/2019	153539	MN Sales and Use Tax Payable	Sales tax payable	604-20210-0000	28,909.51
Total 604202100000:					28,909.51
05/02/2019	51902	Further	VEBA/HSA submittal May	604-49570-1310	60.61 M
Total 604495701310:					60.61
04/30/2019	41928	Reliance Standard	May LTD Insurance	604-49570-1340	3.14 M
Total 604495701340:					3.14
05/02/2019	51903	City of Waseca	April Utilities	604-49570-3800	59.85 M
Total 604495703800:					59.85
05/02/2019	51902	Further	VEBA/HSA submittal May	604-49571-1310	1,337.19 M
Total 604495711310:					1,337.19
04/30/2019	41928	Reliance Standard	May LTD Insurance	604-49571-1340	69.28 M
Total 604495711340:					69.28
05/02/2019	20190340	Bomgaars Supply	Parts & Supplies	604-49571-2170	51.88
05/02/2019	20190341	Border States Electric Supply	Truck Supplies	604-49571-2170	138.15
05/02/2019	20190341	Border States Electric Supply	Lighting Connectors	604-49571-2170	72.69
05/02/2019	153539	MN Sales and Use Tax Payable	Sales tax payable	604-49571-2170	13.85
Total 604495712170:					276.57
05/02/2019	20190387	U.S. Bank - CC	Safety glasses	604-49571-2180	153.14
Total 604495712180:					153.14
05/02/2019	20190376	Owatonna Shoe Company	Safety boots	604-49571-2190	216.75
05/02/2019	20190387	U.S. Bank - CC	Shipping	604-49571-2190	34.26

M = Manual Check, V = Void Check

Check Issue Date	Check Number	Payee	Description	Invoice GL Account	Check Amount
Total 604495712190:					251.01
05/02/2019	20190341	Border States Electric Supply	Meters (6)	604-49571-2215	904.32
05/02/2019	153564	Wesco Receivables Corp	Metering CT's	604-49571-2215	386.55
Total 604495712215:					1,290.87
05/02/2019	153540	MN Valley Action Council	Energy audit reimbursement	604-49571-2340	1,824.94
Total 604495712340:					1,824.94
05/02/2019	20190380	Stuart C. Irby Company	Testing Tools	604-49571-3100	232.98
Total 604495713100:					232.98
05/02/2019	153559	Verizon Wireless	Monthly Billing	604-49571-3200	36.12-
05/02/2019	153559	Verizon Wireless	Monthly Billing	604-49571-3200	136.78
Total 604495713200:					100.66
05/02/2019	51902	Further	VEBA/HSA submittal May	604-49572-1310	134.48 M
Total 604495721310:					134.48
04/30/2019	41928	Reliance Standard	May LTD Insurance	604-49572-1340	6.97 M
Total 604495721340:					6.97
05/02/2019	51902	Further	VEBA/HSA submittal May	604-49573-1310	242.44 M
Total 604495731310:					242.44
04/30/2019	41928	Reliance Standard	May LTD Insurance	604-49573-1340	12.56 M
Total 604495731340:					12.56
05/02/2019	51902	Further	VEBA/HSA submittal May	604-49574-1310	68.19 M
Total 604495741310:					68.19
04/30/2019	41928	Reliance Standard	May LTD Insurance	604-49574-1340	3.53 M
Total 604495741340:					3.53
05/02/2019	20190341	Border States Electric Supply	Supplies	604-49574-2230	232.78
Total 604495742230:					232.78
05/02/2019	51902	Further	VEBA/HSA submittal May	604-49584-1310	51.13 M
Total 604495841310:					51.13
04/30/2019	41928	Reliance Standard	May LTD Insurance	604-49584-1340	2.65 M

M = Manual Check, V = Void Check

Check Issue Date	Check Number	Payee	Description	Invoice GL Account	Check Amount
Total 604495841340:					2.65
05/02/2019	51902	Further	VEBA/HSA submittal May	604-49585-1310	87.24 M
05/02/2019	51902	Further	VEBA/HSA submittal May	604-49585-1310	316.56 M
Total 604495851310:					403.80
04/30/2019	41928	Reliance Standard	May LTD Insurance	604-49585-1340	20.68 M
Total 604495851340:					20.68
05/02/2019	20190360	Innovative Office Supply	Office Supplies	604-49585-2000	6.02
05/02/2019	20190387	U.S. Bank - CC	Replacement parts for phone headsets	604-49585-2000	49.95
05/02/2019	20190387	U.S. Bank - CC	Replacement parts for phone headsets	604-49585-2000	4.64
Total 604495852000:					60.61
05/02/2019	153523	Consolidated Communications	Monthly Billing	604-49585-3200	79.99
05/02/2019	153523	Consolidated Communications	Monthly Billing	604-49585-3200	26.48
05/02/2019	153557	U.S. Postal Service	Postage - May utility bills	604-49585-3200	430.50
Total 604495853200:					536.97
05/02/2019	20190338	APG Media of So MN LLC	Newspaper subscription	604-49585-4330	49.40
Total 604495854330:					49.40
05/02/2019	51902	Further	VEBA/HSA submittal May	604-49586-1310	65.90 M
05/02/2019	51902	Further	VEBA/HSA submittal May	604-49586-1310	171.06 M
Total 604495861310:					236.96
04/30/2019	41928	Reliance Standard	May LTD Insurance	604-49586-1340	3.26 M
04/30/2019	41928	Reliance Standard	May LTD Insurance	604-49586-1340	4.94 M
04/30/2019	41928	Reliance Standard	May LTD Insurance	604-49586-1340	13.34 M
Total 604495861340:					21.54
05/02/2019	153515	Cannon Technologies Inc/Eaton	Yukon Support 2019	604-49586-3000	1,610.63
05/02/2019	153550	Schneider Geospatial	Schneider Geospatial	604-49586-3000	6,095.00
Total 604495863000:					7,705.63
05/02/2019	153551	Shred-it USA LLC	Shredding service	604-49586-3100	77.95
Total 604495863100:					77.95
05/02/2019	20190377	Pantheon Computer Systems Inc.	May Service	604-49586-4950	896.75
Total 604495864950:					896.75
05/02/2019	20190341	Border States Electric Supply	PSB Lights & City Shop Lights	604-49593-5200	4,357.68
Total 604495935200:					4,357.68

M = Manual Check, V = Void Check

Check Issue Date	Check Number	Payee	Description	Invoice GL Account	Check Amount
05/02/2019	153514	BC Electric Service	House Conversions (6)	604-49593-5300	2,212.00
05/02/2019	153514	BC Electric Service	House Conversions (6)	604-49593-5300	1,890.00
05/02/2019	20190341	Border States Electric Supply	Conversion Materials	604-49593-5300	479.01
05/02/2019	20190350	Ditch Witch of Minnesota	Boring Supplies	604-49593-5300	162.00
05/02/2019	20190350	Ditch Witch of Minnesota	Boring Equipment Repairs	604-49593-5300	1,797.54
05/02/2019	20190350	Ditch Witch of Minnesota	Boring Supplies	604-49593-5300	744.02
05/02/2019	20190350	Ditch Witch of Minnesota	Boring Machine Repairs	604-49593-5300	249.96
05/02/2019	20190363	JT Services of MN	LED Project	604-49593-5300	1,370.79
05/02/2019	153539	MN Sales and Use Tax Payable	Sales tax payable	604-49593-5300	2,224.28
05/02/2019	20190387	U.S. Bank - CC	Shelves for stockroom #1910	604-49593-5300	748.56
05/02/2019	20190387	U.S. Bank - CC	Credit for returned items #1910	604-49593-5300	199.64
05/02/2019	20190387	U.S. Bank - CC	Shelving for city hall stock room #1910	604-49593-5300	195.61
05/02/2019	20190387	U.S. Bank - CC	Supplies for city hall bathrooms #1910	604-49593-5300	34.50
Total 604495935300:					11,908.63
Total Electric Utility:					61,601.08
Storm Water Utility					
05/02/2019	51902	Further	VEBA/HSA submittal May	651-43140-1310	215.91 M
Total 651431401310:					215.91
04/30/2019	41928	Reliance Standard	May LTD Insurance	651-43140-1340	10.93 M
Total 651431401340:					10.93
05/02/2019	51903	City of Waseca	April Utilities	651-43140-3800	306.66 M
Total 651431403800:					306.66
05/02/2019	153507	Agri Drain Corporation	Slide Gate	651-43140-4000	777.83
Total 651431404000:					777.83
05/02/2019	51902	Further	VEBA/HSA submittal May	651-49585-1310	49.78 M
Total 651495851310:					49.78
04/30/2019	41928	Reliance Standard	May LTD Insurance	651-49585-1340	3.25 M
Total 651495851340:					3.25
Total Storm Water Utility:					1,364.36
Central Garage Services					
05/02/2019	51902	Further	VEBA/HSA submittal May	701-43180-1310	576.37 M
Total 701431801310:					576.37
04/30/2019	41928	Reliance Standard	May LTD Insurance	701-43180-1340	33.20 M
Total 701431801340:					33.20
05/02/2019	20190340	Bomgaars Supply	Parts & Supplies	701-43180-2170	52.97
05/02/2019	153532	Huber Supply Co Inc	lease on tanks	701-43180-2170	21.48

M = Manual Check, V = Void Check

Check Issue Date	Check Number	Payee	Description	Invoice GL Account	Check Amount
05/02/2019	20190358	IFACS	Shop supplies	701-43180-2170	14.67
05/02/2019	20190358	IFACS	nuts & bolts	701-43180-2170	51.94
05/02/2019	153555	State Chemical Manufacturing Co.	spray paint	701-43180-2170	207.90
05/02/2019	20190381	Terminal Supply Co	shop supplies	701-43180-2170	168.15
05/02/2019	20190387	U.S. Bank - CC	Plastic tote to store spare radios and parts	701-43180-2170	9.98
Total 701431802170:					527.09
05/02/2019	153509	Altec Industries Inc.	hose carrier	701-43180-2210	867.29
05/02/2019	153509	Altec Industries Inc.	large hose carrier	701-43180-2210	132.01
05/02/2019	153512	Auto Value Waseca	Parts	701-43180-2210	407.46
05/02/2019	20190340	Bomgaars Supply	Parts & Supplies	701-43180-2210	84.99-
05/02/2019	153526	Deml Ford Lincoln Mercury Inc	plugs and coil assembly	701-43180-2210	842.10
05/02/2019	20190355	H & L Mesabi	carbide blades	701-43180-2210	1,999.41
05/02/2019	20190356	Harrison Truck Centers	extra step	701-43180-2210	107.00
05/02/2019	20190356	Harrison Truck Centers	step brackets	701-43180-2210	34.48
05/02/2019	153534	Kris Engineering Inc.	Grader blades	701-43180-2210	1,910.36
05/02/2019	153538	Mills Automotive Group	Sensor	701-43180-2210	57.32
05/02/2019	20190382	Tesch Service Center Co.	new tires	701-43180-2210	450.04
05/02/2019	153566	Winegar, Dave	Aluminum pockets for parks trucks	701-43180-2210	360.00
05/02/2019	153566	Winegar, Dave	Spreader carts material	701-43180-2210	165.90
Total 701431802210:					7,248.38
05/02/2019	20190352	GMS Industrial Supplies Inc.	drill bits & supplies	701-43180-2400	64.00
05/02/2019	20190386	Tool Sales Company	Tools	701-43180-2400	29.00
05/02/2019	20190386	Tool Sales Company	small tool	701-43180-2400	10.00
Total 701431802400:					103.00
05/02/2019	20190387	U.S. Bank - CC	Monthly Diagnostic Program	701-43180-3100	149.00
Total 701431803100:					149.00
Total Central Garage Services:					8,637.04
Equipment Replacement Fund					
05/02/2019	153529	Fire Safety USA Inc.	New Truck Loose Equip	705-49930-5400	4,890.00
Total 705499305400:					4,890.00
05/02/2019	153511	Asphalt Zipper Inc.	Asphalt Zipper replacement	705-49950-5400	114,110.00
Total 705499505400:					114,110.00
05/02/2019	153547	PlayTime LLC	Playtime Water Walk	705-49960-5400	5,519.00
Total 705499605400:					5,519.00
Total Equipment Replacement Fund:					124,519.00
Grand Totals:					759,457.72

Report Criteria:

Report type: GL detail

[Report].Amount = {<>} 0



Minnesota Department of Public Safety
 Alcohol and Gambling Enforcement Division
 445 Minnesota Street, Suite 222, St. Paul, MN 55101
 651-201-7500 Fax 651-297-5259 TTY 651-282-6555
**APPLICATION AND PERMIT FOR A 1 DAY
 TO 4 DAY TEMPORARY ON-SALE LIQUOR LICENSE**

Name of organization		Date organized	Tax exempt number
United Prairie Bank		2004	41-0250740
Address	City	State	Zip Code
1509 N State St.	Waseca	Minnesota	56093
Name of person making application		Business phone	Home phone
Amy Watje		507-835-8180	507-835-8180
Date(s) of event	Type of organization		
August 22nd, 2019	<input type="checkbox"/> Club <input type="checkbox"/> Charitable <input type="checkbox"/> Religious <input type="checkbox"/> Other non-profit		
Organization officer's name	City	State	Zip Code
Doug Lago	Waseca	Minnesota	56093
Organization officer's name	City	State	Zip Code
Marcia Buchele	Waseca	Minnesota	56093
Organization officer's name	City	State	Zip Code
		Minnesota	
Organization officer's name	City	State	Zip Code
		Minnesota	

Location where permit will be used. If an outdoor area, describe.
 Bank Lobby at 1509 N State St. Waseca, MN. Hosting Waseca Chamber Business After Hours Event from 4:30-6:30.

If the applicant will contract for intoxicating liquor service give the name and address of the liquor license providing the service.
 NA

If the applicant will carry liquor liability insurance please provide the carrier's name and amount of coverage.
 NA

APPROVAL

APPLICATION MUST BE APPROVED BY CITY OR COUNTY BEFORE SUBMITTING TO ALCOHOL AND GAMBLING ENFORCEMENT

City or County approving the license	Date Approved
Fee Amount	Permit Date
Date Fee Paid	City or County E-mail Address
	City or County Phone Number

Signature City Clerk or County Official _____ Approved Director Alcohol and Gambling Enforcement _____
 CLERKS NOTICE: Submit this form to Alcohol and Gambling Enforcement Division 30 days prior to event.

**ONE SUBMISSION PER EMAIL, APPLICATION ONLY.
 PLEASE PROVIDE A VALID E-MAIL ADDRESS FOR THE CITY/COUNTY AS ALL TEMPORARY PERMIT APPROVALS WILL BE SENT
 BACK VIA EMAIL. E-MAIL THE APPLICATION SIGNED BY CITY/COUNTY TO AGE.TEMPORARYAPPLICATION@STATE.MN.US**



6D

Minnesota Department of Public Safety
 Alcohol and Gambling Enforcement Division
 445 Minnesota Street, Suite 222, St. Paul, MN 55101
 651-201-7500 Fax 651-297-5259 TTY 651-282-6555
**APPLICATION AND PERMIT FOR A 1 DAY
 TO 4 DAY TEMPORARY ON-SALE LIQUOR LICENSE**

Name of organization Date organized Tax exempt number
 SWEET SOMMERS VFW POST 1642 1936 36-4675638

Address City State Zip Code
 113 WEST ELM AVE. WASECA Minnesota 56093

Name of person making application Business phone Home phone
 MICHELLE KAHNKE (507) 835-1811 (507) 461-5262

Date(s) of event Type of organization
 06/09/2019 Club Charitable Religious Other non-profit

Organization officer's name City State Zip Code
 DENNIS PAULSON - COMMANDER WASECA Minnesota 56093

Organization officer's name City State Zip Code
 _____ _____ Minnesota _____

Organization officer's name City State Zip Code
 _____ _____ Minnesota _____

Organization officer's name City State Zip Code
 _____ _____ Minnesota _____

Location where permit will be used. If an outdoor area, describe.

VFW POST 1642 - CLUB

If the applicant will contract for intoxicating liquor service give the name and address of the liquor license providing the service.

If the applicant will carry liquor liability insurance please provide the carrier's name and amount of coverage.

ASSURED PARTNERS OF MINNESOTA
 1,000,000 / 1,000,000

APPROVAL

APPLICATION MUST BE APPROVED BY CITY OR COUNTY BEFORE SUBMITTING TO ALCOHOL AND GAMBLING ENFORCEMENT

 City or County approving the license

 Date Approved

 Fee Amount

 Permit Date

 Date Fee Paid

 City or County E-mail Address

 City or County Phone Number

 Signature City Clerk or County Official

 Approved Director Alcohol and Gambling Enforcement

CLERKS NOTICE: Submit this form to Alcohol and Gambling Enforcement Division 30 days prior to event.

**ONE SUBMISSION PER EMAIL, APPLICATION ONLY.
 PLEASE PROVIDE A VALID E-MAIL ADDRESS FOR THE CITY/COUNTY AS ALL TEMPORARY PERMIT APPROVALS WILL BE SENT
 BACK VIA EMAIL. E-MAIL THE APPLICATION SIGNED BY CITY/COUNTY TO AGE.TEMPORARYAPPLICATION@STATE.MN.US**

CONTRACT CONSTRUCTION PAYMENT REQUEST

DATE: April 25, 2019

TO: Mayor & City Council
Lee Mattson, City Manager

PROJECT NAME: TLCF

CITY PROJECT NO. 2016-23

PAYMENT REQUEST : Final

PAYMENT PERIOD : 26-Feb-19

CONTRACTOR: Britton Plumbing and Heating

PAYMENT AMOUNT: \$2,885.25

Approved By:

Tom Kullberg 4/25/19
Department Head Date

Director of Finance Date
Lee A. Mattson 4-26-19
City Manager Date

RECEIVED

MAR 06 2019

APPLICATION AND CERTIFICATE FOR PAYMENT CONSTRUCTION MANAGER-ADVISER EDITION

AIA DOCUMENT G732/Cma

PAGE ONE OF 2 PAGES

Kraus Anderson

TO OWNER: CITY OF WASECA 508 S. STATE ST. WASECA MN 56093 CONTR ACTOR: BRITTON PLUMBING & HEATING, LLC 10740 340TH AVE WASECA MN 56083 PROJECT: TINK LARSON FIELD 618 4TH ST NE WASECA MN 56093 VIA CONSTRUCTION MANAGER: KRAUS ANDERSON VIA ARCHITECT: WIDSETH SMITH NOLTING & ASSOC APPLICATION NO.: 5 PERIOD TO: 02/26/19 PROJECT NOS. CONTRACT DATE: Distribution to: () OWNER () ARCHITECT () CONTRACTOR () ()

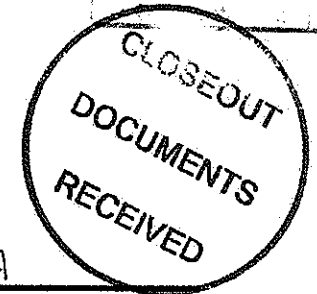

WS 22-A

CONTRACT FOR: GRANDSTAND

CONTRACTOR'S APPLICATION FOR PAYMENT

Application is made for payment, as shown below, in connection with the Contract. Continuation Sheet, AIA Document G703, is attached.

Table with 2 columns: Description and Amount. Rows include: 1. ORIGINAL CONTRACT SUM (\$55,000.00), 2. Net change by Change Orders (\$2,705.00), 3. CONTRACT SUM TO DATE (\$57,705.00), 4. TOTAL COMPLETED & STORED TO DATE (\$57,705.00), 5. RETAINAGE (Total \$0.00), 6. TOTAL EARNED LESS RETAINAGE (\$57,705.00), 7. LESS PREVIOUS CERTIFICATES FOR PAYMENT (\$54,819.75), 8. CURRENT PAYMENT DUE (\$2,885.25), 9. BALANCE TO FINISH, INCLUDING RETAINAGE (\$0.00)

The undersigned Contractor certifies that to the best of the Contractor's knowledge, information and belief the Work covered by this Application for Payment has been completed in accordance with the Contract Documents, that all amounts have been paid by the Contractor for Work for which previous Certificates for Payment were issued and payments received from the Owner, and that current payment shown herein is now due.

CONTRACTOR: By: [Signature]

State of: Minnesota County of: Waseca Subscribed and sworn to before me this 26 day of Feb. 2019

Notary Public: [Signature] My Commission expires: Jan 31, 2024

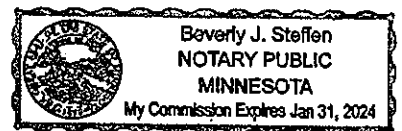

CERTIFICATE FOR PAYMENT

In accordance with the Contract Documents, based on on-site observations and the data comprising this application, the Construction Manager and Architect certifies to the Owner that to the best of their knowledge, information and belief the Work has progressed as indicated, the quality of the Work is in accordance with the Contract Documents, and the Contractor is entitled to payment of the AMOUNT CERTIFIED.

AMOUNT CERTIFIED: 2,885.25

(Attach explanation if amount certified differs from the amount applied for. Initial all figures on this Application and on the Continuation Sheet that are changed to conform to the amount certified.)

CONSTRUCTION MANAGER: By: [Signature] Date: 3-28-19 ARCHITECT: By: _____ Date: _____

This Certificate is not negotiable. The AMOUNT CERTIFIED is payable only to the Contractor named herein. Issuance, payment and acceptance of payment are without prejudice to any rights of the Owner or Contractor under this Contract.

CHANGE ORDER SUMMARY table with columns: ADDITIONS, DEDUCTIONS. Rows: Total changes approved in previous months by Owner (\$0.00), Total approved this Month (\$0.00), TOTALS (\$0.00), NET CHANGES by Change Order (\$0.00)

CONTRACT CONSTRUCTION PAYMENT REQUEST

DATE: April 25, 2019

TO: Mayor & City Council
Lee Mattson, City Manager

PROJECT NAME: T L C F

CITY PROJECT NO. 2016-23

PAYMENT REQUEST : Final

PAYMENT PERIOD : 31-Aug-18

CONTRACTOR: Construction Supply Inc

PAYMENT AMOUNT: \$397.65

Approved By:

Tom Killeen 4/25/19
Department Head Date

Director of Finance Date
Lee A. Mattson 4-26-19
City Manager Date

13118

RECEIVED

APPLICATION AND CERTIFICATE FOR PAYMENT

AIA DOCUMENT G702/CMa

PAGE 1 OF 2

PAGES 9, 8, 2019

TO OWNER: City of Waseca
508 S. State St.
Waseca, MN 56093

PROJECT: Tink Larson Field
Waseca, MN

APPLICATION NO: Retainage

Distribution to:

OWNER

CONSTRUCTION

MANAGER

ARCHITECT

CONTRACTOR

PERIOD TO: 02/20/19

PROJECT NO:

CONTRACT DATE: 9/20/17

FROM CONTRACTOR:

Construction Supply, Inc.
2410 5th Ave North
 Fargo, ND 58102

VIA CONSTRUCTION MANAGER:

Kraus Anderson Constrtuction

CONTRACT FOR:

VIA ARCHITECT:

WS 10-B

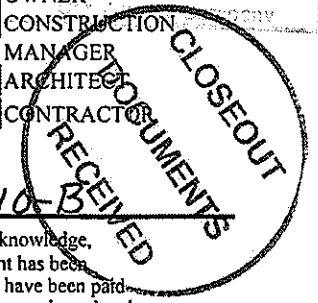

CONTRACTOR'S APPLICATION FOR PAYMENT

Application is made for payment, as shown below, in connection with the Contract. Continuation Sheet, AIA Document G703, is attached.

The undersigned Contractor certifies that to the best of the Contractor's knowledge, information and belief the Work covered by this Application for Payment has been completed in accordance with the Contract Documents, that all amounts have been paid by the Contractor for Work for which previous Certificates for Payment were issued and payments received from the Owner, and that current payment shown herein is now due.

- 1. ORIGINAL CONTRACT SUM \$ 4,253.00
- 2. Net change by Change Orders \$ 185.00
- 3. CONTRACT SUM TO DATE (Line 1 + 2) \$ 4,438.00
- 4. TOTAL COMPLETED & STORED TO DATE \$ 4,438.00
(Column G on G703)
- 5. RETAINAGE:
 - a. 5% % of Completed Work \$ 0.00
(Column D + E on G703)
 - b. % of Stored Material \$
(Column F on G703)
- Total Retainage (Lines 5a + 5b or Total in Column I of G703) \$ 0.00
- 6. TOTAL EARNED LESS RETAINAGE \$ 4,438.00
(Line 4 less Line 5 Total)
- 7. LESS PREVIOUS CERTIFICATES FOR PAYMENT (Line 6 from prior Certificate) \$ 4,040.35
- 8. CURRENT PAYMENT DUE \$ 397.65
- 9. BALANCE TO FINISH, INCLUDING RETAINAGE \$ 0.00
(Line 3 less Line 6)

CONTRACTOR: Construction Supply, Inc.

By: Date: February 20, 2019

State of: North Dakota County of: Cass
Subscribed and sworn to before me this 20th day of February 2019

Notary Public: Rachel Mischenke
My Commission expires: Dec. 08, 2021

RACHEL MISCHKE
Notary Public
STATE OF NORTH DAKOTA
My Commission Expires
December 08, 2021

CERTIFICATE FOR PAYMENT

In accordance with the Contract Documents, based on on-site observations and the data comprising this application, the Construction Manager and Architect certify to the Owner that to the best of their knowledge, information and belief the Work has progressed as indicated, the quality of the Work is in accordance with the Contract Documents, and the Contractor is entitled to payment of the AMOUNT CERTIFIED.

AMOUNT CERTIFIED \$ 397.65

(Attach explanation if amount certified differs from the amount applied for. Initial all figures on this Application and on the Continuation Sheet that changed to conform to the amount certified.)

CONSTRUCTION MANAGER:

By: Date: 3-1-19

ARCHITECT:

By: _____ Date: _____

This Certificate is not negotiable. The AMOUNT CERTIFIED is payable only to the Contractor named herein. Issuance, payment and acceptance of payment are without prejudice to any rights of the Owner or Contractor under this Contract.

CHANGE ORDER SUMMARY	ADDITIONS	DEDUCTIONS
Total changes approved in previous months by Owner		
Total approved this Month		\$0.00
TOTALS	\$185.00	\$0.00
NET CHANGES by Change Order	\$185.00	

CONTRACT CONSTRUCTION PAYMENT REQUEST

DATE: April 29, 2019

TO: Mayor & City Council
Lee Mattson, City Manager

PROJECT NAME: 2018 Street Water Main and Miscellaneous Storm Sewer Improvements

CITY PROJECT NO. 2017-06 and 2018-01

PAYMENT REQUEST : NO. SIX

PAYMENT PERIOD : January 1, 2019 to April 26, 2019

CONTRACTOR: Dirt Merchant, Inc.

PAYMENT AMOUNT: \$ 28,137.86

Approved By:

Tom Kellogg 5/1/19
Department Head Date

Director of Finance Date

City Manager Date

CONTRACT CONSTRUCTION PAYMENT REQUEST

DATE: APRIL 29, 2019

TO: Mayor & City Council
Lee Mattson-City Manager

PROJECT NAME: 2018 STREET, WATER AND MISC. STORM SEWER IMPROVEMENTS

CITY PROJECT NO. : 2017-06 and 2018-01

PAYMENT REQUEST : NO. 6

PAYMENT PERIOD : JANUARY 1, 2019 to APRIL 26, 2019

CONTRACTOR: DIRT MERCHANT, INC.

<u>CONTRACT</u>			<u>PAYMENT</u>	
Original Contract sum:		<u>\$ 1,361,268.22</u>	Contract Sum to date:	<u>\$ 1,383,724.32</u>
Change Orders			Total earned to date (Includes Change Orders)	<u>\$ 1,167,674.19</u>
Change Order #1	8/28/2016	<u>\$ 14,165.25</u>	Retainage: 5%	<u>\$ 58,383.71</u>
Change Order #2	10/29/2018	<u>\$ 3,249.20</u>	Total earned less retainage:	<u>\$ 1,109,290.48</u>
Change Order #3	11/27/2018	<u>\$ 2,881.65</u>	Less previous payment requests:	<u>\$ 1,081,152.62</u>
Change Order #4	2/12/2019	<u>\$ 2,160.00</u>	Payment due this request:	<u>\$ 28,137.86</u>
			% Contract completed to date:	<u>84%</u>
Net change by change orders:		<u>\$ 22,456.10</u>	Amount remaining on contract:	<u>\$ 216,050.13</u>
Contract Sum to date:		<u>\$ 1,383,724.32</u>	Total Amount Due:	<u>\$ 28,137.86</u>

Approved By:

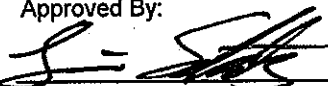
 4-30-19
Contractor Date

Director of Finance Date

 5/1/19
City Engineer Date

City Manager Date

CONTRACT CONSTRUCTION PAYMENT REQUEST

DATE: April 29, 2019

TO: Mayor & City Council
Lee Mattson, City Manager

PROJECT NAME: 2018 Street Water Main and Miscellaneous Storm Sewer Improvements

CITY PROJECT NO. 2017-06 and 2018-01

PAYMENT REQUEST : NO. FIVE

PAYMENT PERIOD : November 24, 2018 to December 31, 2018

CONTRACTOR: Dirt Merchant, Inc.

PAYMENT AMOUNT: \$3,463.26

Approved By:

Tom Kellam 4/30/19
Department Head Date

Director of Finance Date
Lee A. Mattson 4-30-19
City Manager Date

CONTRACT CONSTRUCTION PAYMENT REQUEST

DATE: FEBRUARY 12, 2019

TO: Mayor & City Council
Lee Mattson-City Manager

PROJECT NAME: 2018 STREET, WATER AND MISC. STORM SEWER IMPROVEMENTS

CITY PROJECT NO. : 2017-06 and 2018-01

PAYMENT REQUEST : NO. 5

PAYMENT PERIOD : NOVEMBER 24, 2018 to FEBRUARY 8, 2019

CONTRACTOR: DIRT MERCHANT, INC.

<u>CONTRACT</u>			<u>PAYMENT</u>	
Original Contract sum:		<u>\$ 1,361,268.22</u>	Contract Sum to date:	<u>\$ 1,383,724.32</u>
Change Orders			Total earned to date (Includes Change Orders)	<u>\$ 1,138,055.39</u>
Change Order #1	8/28/2016	<u>\$ 14,165.25</u>	Retainage: 5%	<u>\$ 56,902.77</u>
Change Order #2	10/29/2018	<u>\$ 3,249.20</u>	Total earned less retainage:	<u>\$ 1,081,152.62</u>
Change Order #3	11/27/2018	<u>\$ 2,881.65</u>	Less previous payment requests:	<u>\$ 1,077,689.36</u>
Change Order #4	2/12/2019	<u>\$ 2,160.00</u>	Payment due this request:	<u>\$ 3,463.26</u>
			% Contract completed to date:	<u>82%</u>
Net change by change orders:		<u>\$ 22,456.10</u>	Amount remaining on contract:	<u>\$ 245,668.93</u>
Contract Sum to date:		<u>\$ 1,383,724.32</u>	Total Amount Due:	<u>\$ 3,463.26</u>

Approved By:

 4-12-19
Contractor Date

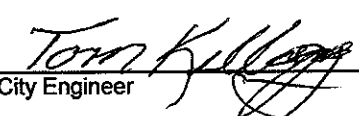
 4/30/19
City Engineer Date

Director of Finance Date

 4-30-19
City Manager Date

CHANGE ORDER

CHANGE ORDER NO. FOUR

CITY OF WASECA PROJECT NO. 2018-01

DATE: FEBRUARY 12, 2019

PROJECT NAME: 2018 STREET, WATER, & MISCELLANEOUS STORM IMPROVEMENTS

CONTRACTOR: DIRT MERCHANT INC.
3301 THIRD AVENUE
MANKATO, MN 56001

THE JUSTIFICATION FOR THIS CHANGE ORDER IS:

Due to planned electrical utility reconstruction in the spring of 2019, the City asked the contractor to delay placement of sod on 7th Ave SE until 2019, and to place hydromulch in order to stabilize the disturbed soils. There was no item in the contract quantities for the hydromulch.

ITEM	UNIT	QTY.	UNIT PRICE	TOTAL PRICE
7TH AVE SE				
HYDROMULCH	L.S.	1	\$2,160.00	\$2,160.00
TOTAL CHANGE ORDER NO. THREE				\$2,160.00

ORIGINAL CONTRACT PRICE	\$1,361,268.22
PREVIOUS CHANGE ORDERS	\$20,296.10
AMOUNT OF THIS CHANGE ORDER	\$2,160.00
REVISED CONTRACT AMOUNT	\$1,383,724.32

APPROVED BY:

4-12-19

 CONTRACTOR DATE

4/12/19

 CITY ENGINEER DATE

DIRECTOR OF FINANCE DATE

CITY MANAGER DATE

CONTRACT CONSTRUCTION PAYMENT REQUEST

DATE: April 25, 2019

TO: Mayor & City Council
Lee Mattson, City Manager

PROJECT NAME: TLCF

CITY PROJECT NO. 2016-23

PAYMENT REQUEST: Final

PAYMENT PERIOD: 31-Aug-18

CONTRACTOR: Koronis Fabricating Inc

PAYMENT AMOUNT: \$14,457.50

Approved By:

Tom Kullberg 4/25/19
Department Head Date

Director of Finance Date

Lee Mattson 4-26-19
City Manager Date



AIA Document G732™ - 2009

13118

SEP 10 2018

Application and Certificate for Payment, Construction Manager as Adviser Edition

TO OWNER: City of Waseca 508 S State St Waseca, MN 56093	PROJECT: Tink Larson Field Waseca, MN	APPLICATION NO: 001
FROM CONTRACTOR: Koronis Fabricating Inc 55 E Fifth St #1250 St. Paul, MN 55101	VIA CONSTRUCTION MANAGER: Kraus Anderson	PERIOD TO: 8/1/18 CONTRACT DATE: PROJECT NOS: / /
CONTRACT FOR: St. Paul, MN 55101		VIA ARCHITECT: Wiseth Smith Nolting & Assoc.

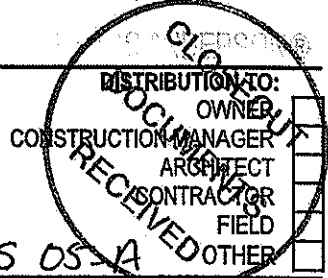

CONTRACTOR'S APPLICATION FOR PAYMENT

Application is made for payment, as shown below, in connection with the Contract. AIA Document G703™, Continuation Sheet, is attached.

1. ORIGINAL CONTRACT SUM.....	\$	77750
2. NET CHANGES IN THE WORK.....	\$	10,570.00
3. CONTRACT SUM TO DATE (Line 1 ± 2)	\$	88,320.00
4. TOTAL COMPLETED AND STORED TO DATE (Column G on G703)	\$	88,320.00
5. RETAINAGE:		
a. 5 % of Completed Work (Column D + E on G703)	\$	0.00
b. % of Stored Material (Column F on G703)	\$	
Total Retainage (Lines 5a + 5b, or Total in Column I on G703)	\$	0.00
6. TOTAL EARNED LESS RETAINAGE.....	\$	88,320.00
(Line 4 minus Line 5 Total)		
7. LESS PREVIOUS CERTIFICATES FOR PAYMENT.....	\$	73,862.50
(Line 6 from prior Certificate)		
8. CURRENT PAYMENT DUE.....	\$	14,457.50
9. BALANCE TO FINISH, INCLUDING RETAINAGE	\$	0.00
(Line 3 minus Line 6)		

The undersigned Contractor certifies that to the best of the Contractor's knowledge, information and belief the Work covered by this Application for Payment has been completed in accordance with the Contract Documents, that all amounts have been paid by the Contractor for Work for which previous Certificates for Payment were issued and payments received from the Owner, and that current payment shown herein is now due.

CONTRACTOR, By: [Signature] Date: 8/20/18

State of: Minnesota
County of: Ramsey
Subscribed and sworn to before me this 20th day of August, 2018
Notary Public: [Signature]
My Commission expires: 01/31/2022

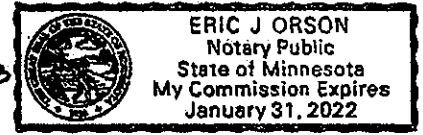

CERTIFICATE FOR PAYMENT

In accordance with the Contract Documents, based on evaluations of the Work and the data comprising this application, the Construction Manager and Architect certify to the Owner that to the best of their knowledge, information and belief the Work has progressed as indicated, the quality of the Work is in accordance with the Contract Documents, and the Contractor is entitled to payment of the AMOUNT CERTIFIED.

AMOUNT CERTIFIED.....\$ 14,457.50
(Attach explanation if amount certified differs from the amount applied. Initial all figures on this Application and on the Continuation Sheet that are changed to conform with the amount certified.)

CONSTRUCTION MANAGER: By: [Signature] Date: 3/28/19

ARCHITECT: (NOTE: If Multiple Prime Contractors are responsible for performing portions of the Project, the Architect's Certification is not required.)

By: _____ Date: _____
This Certificate is not negotiable. The AMOUNT CERTIFIED is payable only to the Contractor named herein. Issuance, payment and acceptance of payment are without prejudice to any rights of the Owner or Contractor under this Contract.

SUMMARY OF CHANGES IN THE WORK	ADDITIONS	DEDUCTIONS
Total changes approved in previous months by Owner	\$	\$
Total approved this month, including Construction Change Directives	\$ 10891	\$
TOTALS	\$ 10891	\$
NET CHANGES IN THE WORK	\$	10891

CONTRACT CONSTRUCTION PAYMENT REQUEST

DATE: April 25, 2019

TO: Mayor & City Council
Lee Mattson, City Manager

PROJECT NAME: TLCF

CITY PROJECT NO. 2016-23

PAYMENT REQUEST: Final

PAYMENT PERIOD: 31-Aug-18

CONTRACTOR: Merit Contracting Inc

PAYMENT AMOUNT: \$8,129.86

Approved By:

 4/25/19

Department Head Date

Director of Finance Date
 4-26-19

City Manager Date

13/18

APPLICATION AND CERTIFICATION FOR PAYMENT, Construction Manager as Adviser Edition

PAGE 1 OF 2 PAGES

MAR 18 2019

TO OWNER: City of Waseca
508 S State ST
Waseca MN 56093

PROJECT:
Tink Larson Field
Waseca MN

APPLICATION NO: 3

Distribution to:

- OWNER
- CONSTRUCTION MANAGER
- ARCHITECT
- CONTRACTOR
- FIELD
- OTHER

FROM CONTRACTOR:
Merit Contracting, Inc.
4661 Hadley View Ct NE
Rochester MN 55906

VIA CONSTRUCTION MANAGER:
Kraus Anderson Company
416 S Broadway
Rochester MN 55904

PERIOD TO: 08/31/18
CONTRACT DATE: 816/17
PROJECT NOS: 1711014

CONTRACT FOR: metal roof panel package

VIA ARCHITECT: Widseth Smith Nolting & Assoc

WS 07-B

CONTRACTOR'S APPLICATION FOR PAYMENT

Application is made for payment, as shown below, in connection with the Contract Continuation Sheet, AIA Document G703™, continuatio Sheet, is attached.

1. ORIGINAL CONTRACT SUM	\$	54,126.00
2. NET CHANGES IN THE WORK	\$	7,084.59
3. CONTRACT SUM TO DATE (Line 1 +/- 2)	\$	61,210.59
4. TOTAL COMPLETED & STORED TO DATE (Column G on G703)	\$	61,210.59
5. RETAINAGE:		
a. 5 % of Completed Work	\$	0.00
(Column D + E on G703)		
b. 5 % of Stored Material	\$	0.00
(Column F on G703)		
Total Retainage (Lines 5a + 5b, or total in Column I on G703)	\$	0.00
6. TOTAL EARNED LESS RETAINAGE	\$	61,210.59
(Line 4 less Line 5 Total)		
7. LESS PREVIOUS CERTIFICATES FOR PAYMENT	\$	53,080.73
(Line 6 from prior Certificate)		
8. CURRENT PAYMENT DUE	\$	8,129.86
9. BALANCE TO FINISH, INCLUDING RETAINAGE	\$	0.00
(Line 3 minus Line 6)		

The undersigned Contractor certifies that to the best of the Contractor's knowledge, information and belief the Work covered by this Application for Payment has been completed in accordance with the Contract Documents, that all amounts have been paid by the Contractor for Work for which previous Certificates for Payment were issued and payments received from the Owner, and that current payment shown herein is now due.

CONTRACTOR:

By:  Date: 8/24/18

State of Minnesota County of Olmsted
Subscribed and sworn to before me this day of
Notary Public:
My Commission expires:

CERTIFICATE FOR PAYMENT

In accordance with the Contract Documents, based on evaluations of the Work and the data comprising this application, the Construction Manager and Architect certify to the Owner that to the best of their knowledge, information and belief the Work has progressed as indicated, the quality of the Work in accordance with the Contract Documents, and the Contractor is entitled to payment of the AMOUNT CERTIFIED.

AMOUNT CERTIFIED \$ 8,129.86

(Attach explanation if amount certified differs from the amount applied. Initial all figures on this Application and on the Continuation Sheet that are changed to conform with the amount certified.)

CONSTRUCTION MANAGER:

By:  Date: 3-28-19

ARCHITECT: (NOTE: If Multiple Prime Contractors are responsible for performing portions of the Project, the Architect's Certification is not required.)

By: _____ Date: _____

This Certificate is not negotiable. The AMOUNT CERTIFIED is payable only to the Contractor named herein. Issuance, payment and acceptance of payment are without prejudice to any rights of the Owner or Contractor under this Contract.

SUMMARY OF CHANGES IN THE WORK	ADDITIONS	DEDUCTIONS
Total changes approved in previous months by Owner	\$5,313.45	
Total approved this month including Construction Change Directives		
TOTALS	\$5,313.45	\$0.00
NET CHANGES IN THE WORK		\$5,313.45

Title:	RESOLUTION NO. 19-20 AUTHORIZING THE EXECUTION OF THE AIRPORT MAINTENANCE AND OPERATION GRANT AGREEMENT		
Meeting Date:	May 7, 2019	Agenda Item Number:	6F
Action:	<input type="checkbox"/> MOTION <input type="checkbox"/> REQUESTS/PRESENTATIONS <input checked="" type="checkbox"/> RESOLUTION <input type="checkbox"/> ORDINANCE <input type="checkbox"/> DISCUSSION	Supporting Documents:	Resolution No. 19-20
Originating Department:	Engineering	Presented By:	City Engineer
Approved By City Manager: <input checked="" type="checkbox"/>	Proposed Action: Adopt Resolution No. 19-20 Authorizing the Execution of the Airport Maintenance and Operation Grant Agreement.		
How does this item pertain to Vision 2030 goals?	Creating High Quality Community Assets		

BACKGROUND: Minnesota statutes authorize the State to provide financial assistance to airports for maintenance and operation activities. The maintenance and operation grant agreements span two calendar years with the current agreement expiring June 30, 2019. Adopting the attached resolution will continue the grant agreement from July 1, 2019 through June 30, 2021.

BUDGET IMPACT: The City receives approximately \$21,000 annually from the airport maintenance and operation grant agreement.

RECOMMENDATION: Staff recommends the Waseca City Council make a motion to adopt Resolution No. 19-20 authorizing the execution of the airport maintenance and operation agreement.

**RESOLUTION
19-20
AUTHORIZATION TO EXECUTE
MINNESOTA DEPARTMENT OF TRANSPORTATION
AIRPORT MAINTENANCE AND OPERATION GRANT CONTRACT**

It is resolved by the City of Waseca as follows:

1. That the state of Minnesota Contract Number 1033564,

"Airport Maintenance and Operation Grant Contract," at the

Waseca Municipal Airport is accepted.

2. That the _____ and _____ are
(Mayor, Chairperson, President, etc.) (Clerk, Auditor, Secretary, etc.)

authorized to execute this Contract and any amendments on behalf of the

City of Waseca.

CERTIFICATION

STATE OF MINNESOTA

COUNTY OF _____

I certify that the above Resolution is a true and correct copy of the Resolution adopted by the

(Name of the Recipient)

at an authorized meeting held on the _____ day of _____, 20____

as shown by the minutes of the meeting in my possession.

Signature: _____
(Clerk or Equivalent)

CORPORATE SEAL

/OR/

NOTARY PUBLIC

My Commission Expires: _____

**STATE OF MINNESOTA
AIRPORT MAINTENANCE AND OPERATION GRANT CONTRACT**

State Project Number (S.P.): A8101-MO20

State Project Number (S.P.): A8101-MO21

This contract is between the State of Minnesota, acting through its Commissioner of Transportation (“State”) and City of Waseca acting through its City Council (“Recipient”).

RECITALS

1. Minnesota Statutes §§360.015 and 360.305 authorize State to provide financial assistance to airports for maintenance and operation activities.
2. Recipient owns, operates, or controls an airport (“Airport”) in the state system, and Recipient desires financial assistance from the State for maintenance and operation activities for State Fiscal Year 2020 and State Fiscal Year 2021.
3. Recipient represents that it is duly qualified and agrees to perform all services described in this contract to the satisfaction of the State.

CONTRACT TERMS

1. Term of Contract and Survival of Terms

- 1.1. **Effective Date:** This contract will be effective on July 1, 2019, or the date State obtains all required signatures under Minnesota Statutes §16B.98, subdivision 5, whichever is later. As required by Minnesota Statutes §16B.98 Subd. 7, no payments will be made to Recipient until this contract is fully executed.
- 1.2. **Expiration Date:** This contract will expire on June 30, 2021.
- 1.3. **Survival of Terms:** All clauses which impose obligations continuing in their nature and which must survive in order to give effect to their meaning will survive the expiration or termination of this contract, including, without limitation, the following clauses: 9. Indemnification; 10. State Audits; 11. Government Data Practices; 13. Governing Law, Jurisdiction and Venue; and 14. Data Disclosure.

2. Recipient’s Duties

- 2.1. Recipient will operate and maintain the Airport in a safe, serviceable manner for aeronautical purposes only for the use and benefit of the public.
- 2.2. The Recipient will keep the runway and the area around the lights mowed at the Airport. The grass must be mowed at least 7 feet beyond the lights, and the grass must not exceed 6 inches in height on the landing area. The areas around any navigational aids will be mowed and plowed to keep the area clear for access by a vehicle.
- 2.3. If the Airport remains operational during the winter months, the Recipient will keep at least one runway, associated taxiway, and apron area cleared of snow and ice to the same priority as arterial roads. Snow banks must be limited in height so that aircraft wings, engines, and propellers will clear them. Landing strip markers and/or lights must remain visible.

- 2.4. If the State contracts for the periodic paint striping of the Airport's runways and taxiways during the term of this Contract, the Recipient will cooperate with the marking operation. The Recipient must coordinate seal coat pavement maintenance projects with the State to maximize the pavement marking life.
- 2.5. The Recipient will allow a representative of the State's Office of Aeronautics access to any area of the Airport necessary for the purpose of periodic inspections.
- 2.6. The Recipient will promptly pay all utility bills, including those required for navigational aids.

3. Recipient's Assurances

- 3.1. In accordance with Minnesota Statutes § 360.305, subdivision 4, Recipient assures the State that Recipient will operate and maintain the Airport in a safe, serviceable manner for public aeronautical purposes only for a period of one year from the date the Recipient receives final reimbursement under this contract.
- 3.2. Recipient represents and warrants that Recipient has established a zoning authority for the Airport, and such authority has completed, or is in the process of and will complete, with due diligence, an airport zoning ordinance in accordance with Minnesota Statutes §§ 360.061 to 360.074.
- 3.3. Recipient will comply with all required grants management policies and procedures set forth through Minnesota Statutes §16B.97, Subd. 4 (a) (1).

4. Third-Party Contracting

- 4.1. Recipient will comply with all applicable local, state, or federal laws, regulations, policies and procedures in the procurement of goods and services funded in whole or in part under this Contract.

5. Consideration and Payment

- 5.1. **Consideration.** State will pay for all eligible telecommunication, maintenance, and operation costs incurred by Recipient under this Contract as follows:
 - 5.1.1. **Basis.** Recipient will be reimbursed for 100% of telecommunication costs associated with the operation of state-owned navigational aids. Recipient will be paid for 75% of all other eligible maintenance and operation costs not reimbursed by any other source. Eligible maintenance and operations costs will be determined at the sole discretion of State's Authorized Representative.
 - 5.1.2. **Telecommunication Amount.** State has currently obligated \$0.00 in each State fiscal year to reimburse eligible telecommunication costs at 100%.
 - 5.1.3. **Maintenance and Operation Amount.** State has currently obligated \$22,013 in each State fiscal year to reimburse other eligible costs at 75%.
 - 5.1.4. **Total Obligation.** The total obligation of State for all compensation and reimbursements to Recipient under this contract will not exceed \$44,026 (State fiscal years 2020 and 2021).
- 5.2. **Payment.**
 - 5.2.1. **Invoices.** The Recipient must submit a reimbursement request of its eligible costs to the Director of the Office of Aeronautics on a quarterly basis or as directed by State's Authorized Representative. The State's Office of Aeronautics will supply the reimbursement request forms which Recipient must submit. Reimbursement requests must be submitted according to the following schedule:
 - On or after October 1, **and no later than November 15**, for the period July 1 through September 30.
 - On or after January 1, **and no later than February 15**, for the period October 1 through December 31.
 - On or after April 1, **and no later than May 15**, for the period January 1 through March 31.
 - On or after July 1, **and no later than August 15**, for the period April 1 through June 30.

The State may reject costs that the State determines are not eligible maintenance and operations expenses.
 - 5.2.2. **All Invoices Subject to Audit.** All invoices are subject to audit, at State's discretion.

- 5.2.3. **State's Payment Requirements.** State will promptly pay all valid obligations under this contract as required by Minnesota Statutes §16A.124. State will make undisputed payments no later than 30 days after receiving Recipient's invoices and progress reports for services performed. If an invoice is incorrect, defective or otherwise improper, State will notify Recipient within ten days of discovering the error. After State receives the corrected invoice, State will pay Recipient within 30 days of receipt of such invoice.
- 5.2.4. **Grant Monitoring Visit and Financial Reconciliation.** If State's total obligation is greater than \$50,000 in section 5.1.4, above, during the period of performance the State will make at least one monitoring visit and conduct annual financial reconciliations of Recipient's expenditures. The State's Authorized Representative will notify Recipient's Authorized Representative where and when any monitoring visit and financial reconciliation will take place, which State employees and/or contractors will participate, and which Recipient staff members should be present. Recipient will be provided notice prior to any monitoring visit or financial reconciliation. Following a monitoring visit or financial reconciliation, Recipient will take timely and appropriate action on all deficiencies identified by State. At least one monitoring visit and one financial reconciliation must be completed prior to final payment being made to Recipient.
- 5.2.5. **Closeout.** The State will determine, at its sole discretion, whether a closeout audit is required prior to final payment approval. If a closeout audit is required, final payment will be held until the audit has been completed. Monitoring of any capital assets acquired with grant funds will continue following grant closeout.

6. Conditions of Payment

- 6.1. All services provided by Recipient under this contract must be performed to State's satisfaction, as determined at the sole discretion of State's Authorized Representative and in accordance with all applicable federal, state and local laws, ordinances, rules and regulations, including business registration requirements of the Office of the Secretary of State. Recipient will not receive payment for work found by State to be unsatisfactory or performed in violation of federal, state or local law. In addition to the foregoing, Recipient will not receive payment for Airport's failure to pass periodic inspections by a representative of the State's Office of Aeronautics.

7. Authorized Representatives

- 7.1. **State's Authorized Representative.** State's Authorized Representative will be:

Name/Title: Jenny Bahneman, Grants Specialist
Address: Office of Aeronautics, 222 East Plato Boulevard
Telephone: (651) 234-7240
E-Mail: jenny.bahneman@state.mn.us

State's Authorized Representative or his /her successor, will monitor Recipient's performance and has the authority to accept or reject the services provided under this contract. If the Recipient's duties are performed in a satisfactory manner, the State's Authorized Representative will accept each reimbursement request submitted for payment.

- 7.2. **Recipient's Authorized Representative.** Recipient's Authorized Representative will be:

Name/Title: Tom Kellogg, City Engineer
Address: 508 South State Street, Waseca, MN 56093
Telephone: (507) 835-9700
E-Mail: cityengineer@ci.waseca.mn.us

If Recipient's Authorized Representative changes at any time during this contract, Recipient must immediately notify State.

8. Assignment, Amendments, Waiver and Contract Complete

- 8.1. **Assignment.** Recipient may neither assign nor transfer any rights or obligations under this contract without the prior consent of State and a fully executed Assignment Contract, executed and approved by the same parties who executed and approved this contract, or their successors in office.
- 8.2. **Amendments.** An amendment to this contract must be in writing and will not be effective until it has been executed and approved by the same parties who executed and approved the original contract, or their successors in office.
- 8.3. **Waiver.** If State fails to enforce any provision of this contract that failure does not waive the provision or State's right to subsequently enforce it.
- 8.4. **Contract Complete.** This contract contains all prior negotiations and agreements between State and Recipient. No other prior understanding regarding this contract, whether written or oral, may be used to bind either party.

9. Indemnification

- 9.1. In the performance of this contract by Recipient, or Recipient's agents or employees, Recipient must indemnify, save and hold State, its agents, and employees harmless from any and all claims or causes of action, including reasonable attorney's fees incurred by State, to the extent caused by Recipient's: 1) intentional, willful or negligent acts or omissions; 2) breach of contract or warranty; or 3) breach of the applicable standard of care. The indemnification obligations of this section do not apply if the claim or cause of action is the result of State's sole negligence. This clause will not be construed to bar any legal remedies Recipient may have for State's failure to fulfill its obligation pursuant to this contract.

10. State Audits

- 10.1. Under Minnesota Statutes § 16B.98, Subd.8, the Recipient's books, records, documents, and accounting procedures and practices of Recipient, or other party relevant to this grant contract or transaction, are subject to examination by the State and/or the State Auditor or Legislative Auditor, as appropriate, for a minimum of six years from the end of this contract or receipt and approval of all final reports, whichever is later. Recipient will take timely and appropriate action on all deficiencies identified by an audit.

11. Government Data Practices

- 11.1. Recipient and State must comply with the Minnesota Government Data Practices Act, Minnesota Statutes Chapter 13, as it applies to all data provided by State under this contract, and as it applies to all data created, collected, received, stored, used, maintained or disseminated by Recipient under this contract. The civil remedies of Minnesota Statutes §13.08 apply to the release of the data referred to in this clause by either Recipient or State. If Recipient receives a request to release the data referred to in this Clause, Recipient must immediately notify State and consult with State as to how Recipient should respond to the request. Recipient's response to the request must comply with applicable law.

12. Workers' Compensation

- 12.1. Recipient certifies that it is in compliance with Minnesota Statutes §176.181, subdivision 2, pertaining to workers' compensation insurance coverage. Recipient's employees and agents will not be considered State employees. Any claims that may arise under the Minnesota Workers' Compensation Act on behalf of these employees and any claims made by any third party as a consequence of any act or omission on the part of these employees are in no way the State's obligation or responsibility.

13. Governing Law, Jurisdiction and Venue

- 13.1. Minnesota law, without regard to its choice-of-law provisions, governs this contract. Venue for all legal proceedings arising out of this contract, or its breach, must be in the appropriate state or federal court with competent jurisdiction in Ramsey County, Minnesota.

14. Data Disclosure

- 14.1. Under Minnesota Statutes §270C.65, and other applicable law, Recipient consents to disclosure of its social security number, federal employer tax identification number and Minnesota tax identification number, already provided to State, to federal and state agencies and state personnel involved in the payment of state obligations. These identification numbers may be used in the enforcement of federal and state laws which could result in

action requiring Recipient to file state tax returns and pay delinquent state tax liabilities, if any, or pay other state liabilities.

15. Termination and Suspension

- 15.1. **Termination by the State.** The State may terminate this contract with or without cause, upon 30 days written notice to the Recipient. Upon termination, the Recipient will be entitled to payment, determined on a pro rata basis, for services satisfactorily performed.
- 15.2. **Termination for Cause.** The State may immediately terminate this grant contract if the State finds that there has been a failure to comply with the provisions of this contract, that reasonable progress has not been made, that fraudulent or wasteful activity has occurred, that Recipient has been convicted of a criminal offense relating to a state grant agreement, or that the purposes for which the funds were granted have not been or will not be fulfilled. The State may take action to protect the interests of the State of Minnesota, including the refusal to disburse additional funds and requiring the return of all or part of the funds already disbursed.
- 15.3. **Termination for Insufficient Funding.** The State may immediately terminate this contract if: It does not obtain funding from the Minnesota Legislature; or If funding cannot be continued at a level sufficient to allow for the payment of the services covered here. Termination must be by written or fax notice to the Recipient. The State is not obligated to pay for any services that are provided after notice and effective date of termination. However, the Recipient will be entitled to payment, determined on a pro rata basis, for services satisfactorily performed to the extent that funds are available. The State will not be assessed any penalty if the contract is terminated because of the decision of the Minnesota Legislature, or other funding source, not to appropriate funds. The State will provide the Recipient notice of the lack of funding within a reasonable time of the State's receiving that notice.
- 15.4. **Suspension.** The State may immediately suspend this contract in the event of a total or partial government shutdown due to the failure to have an approved budget by the legal deadline. Work performed by the Recipient during a period of suspension will be deemed unauthorized and undertaken at risk of non-payment.

16. Discrimination Prohibited by Minnesota Statutes §181.59

- 16.1. Recipient will comply with the provisions of Minnesota Statutes §181.59 which requires that every contract for or on behalf of the State of Minnesota, or any county, city, town, township, school, school district or any other district in the state, for materials, supplies or construction will contain provisions by which Contractor agrees: 1) That, in the hiring of common or skilled labor for the performance of any work under any contract, or any subcontract, no Contractor, material supplier or vendor, will, by reason of race, creed or color, discriminate against the person or persons who are citizens of the United States or resident aliens who are qualified and available to perform the work to which the employment relates; 2) That no Contractor, material supplier, or vendor, will, in any manner, discriminate against, or intimidate, or prevent the employment of any person or persons identified in clause 1 of this section, or on being hired, prevent or conspire to prevent, the person or persons from the performance of work under any contract on account of race, creed or color; 3) That a violation of this section is a misdemeanor; and 4) That this contract may be canceled or terminated by the state of Minnesota, or any county, city, town, township, school, school district or any other person authorized to grant contracts for employment, and all money due, or to become due under the contract, may be forfeited for a second or any subsequent violation of the terms or conditions of this contract.

17. Limitation.

- 17.1. Under this contract, the State is only responsible for disbursing funds. Nothing in this contract will be construed to make the State a principal, co-principal, partner, or joint venturer with respect to the Project(s) covered herein. The State may provide technical advice and assistance as requested by the Recipient, however, the Recipient will remain responsible for providing direction to its contractors and consultants and for administering its contracts with such entities. The Recipient's consultants and contractors are not intended to be third party beneficiaries of this contract.

THE BALANCE OF THIS PAGE HAS BEEN INTENTIONALLY LEFT BLANK

STATE ENCUMBRANCE VERIFICATION

Individual certifies that funds have been encumbered as required by Minnesota Statutes §16A.15 and §16C.05.*

Signed: _____

Date: _____

SWIFT Contract (SC) ID No. _____

Purchase Order (PO) ID No. _____

*PO staged and to be encumbered with future State fiscal year funds.

RECIPIENT

Recipient certifies that the appropriate person(s) have executed Contracts on behalf of Recipient as required by applicable articles, bylaws or resolutions.

By: _____

Title: _____

Date: _____

By: _____

Title: _____

Date: _____

DEPARTMENT OF TRANSPORTATION

By: _____
(with delegated authority)

Title: _____

Date: _____

MnDOT OFFICE OF FINANCIAL MANAGEMENT – GRANT UNIT

By: _____

Date: _____

MnDOT CONTRACT MANAGEMENT

By: _____

Date: _____

Title:	Ordinance #1071 Amending Chapter 96 & Public Hearing: Prohibiting Acts of the Waseca Code of Ordinances		
Meeting Date:	May 7, 2019	Agenda Item Number:	7A
Action:	<input type="checkbox"/> MOTION <input type="checkbox"/> REQUESTS/PRESENTATIONS <input type="checkbox"/> RESOLUTION <input checked="" type="checkbox"/> ORDINANCE <input checked="" type="checkbox"/> DISCUSSION	Supporting Documents:	Draft Ordinance
Originating Department:	Administration	Presented By:	City Manager
Approved By City Manager: <input checked="" type="checkbox"/>	Proposed Action: Review the proposed ordinance and hold a public hearing and determine the Ordinance Language #1071.		
How does this item pertain to Vision 2030 goals?	This proposal would cause city policy to revert to the status that existed prior to the adoption of the current liquor ordinance in 2017. The intent is to increase the attractiveness of City Parks for use by all residents, creating high quality and desirable community assets.		

BACKGROUND: Staff believes that as part of the adoption of the 2017 Alcoholic Beverages Ordinance, the City Council inadvertently adopted language that prohibited alcohol in most City Parks. The ordinance prohibited the consumption of intoxicating liquor or 3.2% malt liquor in any public plane, which the City Attorney reads to include all parks. The ordinance does allow consumption, “where the consumption and display of liquor is lawfully permitted.” By amending the Park Ordinance, the City could permit the consumption of alcohol in most parks. Please note that the ordinance prohibits alcohol on beaches and anywhere on Tink Larson Field Park. The ordinance also prohibits alcohol at Maplewood Park without the City granting permission.

BUDGET IMPACT: None

POLICY QUESTION: Should alcohol be permitted in City Parks?

ALTERNATIVES CONSIDERED: Status quo that essentially prohibits alcohol, limiting alcohol in more city parks, no limit on what parks may have alcohol.

RECOMMENDATION: Staff and the City Attorney will be present to present background information on this issue. Hold a public hearing. The Council may amend the ordinance, approve it as presented, or decline to amend the ordinance.

ORDINANCE NO. 1071

AN ORDINANCE AMENDING CHAPTER 96; PROHIBITED ACTS OF THE WASECA CODE OF ORDINANCES REGARDING VERBAGE OF SECTION 96.04 (9)

WHEREAS, Chapter 96 of the Waseca Code of Ordinances provides information regarding public parks for the City of Waseca; and

WHEREAS, as part of the adoption of the 2017 Alcoholic Beverages Ordinance, the City Council inadvertently adopted language that prohibited alcohol in most City Parks. The ordinance does allow consumption, “where the consumption and display of liquor is lawfully permitted.”

WHEREAS, by amending the Park Ordinance, the City could permit the consumption of alcohol in most parks.

NOW, THEREFORE, the City of Waseca does hereby ordain that the amendments to Chapter 96 of the Waseca Code of Ordinances as shown here-in are hereby approved and modified. The modification only amends the specified codes, the remainder of the Ordinance shall remain as previously adopted.

SECTION 1. Chapter 96, Public Parks, of the Waseca Code of Ordinances is hereby amended as follows, underlined text is being added and ~~text~~ is being deleted:

§ 96.04 PROHIBITED ACTS.

- (9) ~~No person shall possess, display or consume intoxicating liquors or 3.2 malt liquors on any beaches within city parks, and the possession or consumption of intoxicating or 3.2 malt liquor is allowed in Maplewood Park only upon issuance of a permit by the city.~~

The display and consumption of intoxicating liquors, 3.2 malt liquors, and malt beverages shall be allowed in city parks with the exception that no person shall possess, display or consume intoxicating liquors, 3.2 malt liquors, or malt beverages on any beach within a city park, other than to load or unload a boat on the lake; within the confines of Maplewood Park, unless allowed by permit; or within Tink Larson Community Field Park.

SECTION 2. This Ordinance shall take and be in force 10 days after its passage.

ADOPTED this 7th day of May 2019.

R. D. SRP
MAYOR

ATTEST:

MIKE ANDERSON
ASSISTANT TO THE CITY MANAGER

Introduced: April 16, 2019
Adopted: May 7, 2019
Published: May 17, 2019
Effective: May 17, 2019

CONTRACT CONSTRUCTION PAYMENT REQUEST

DATE: April 29, 2019

TO: Mayor & City Council
Lee Mattson, City Manager

PROJECT NAME: 2017 Sidewalk Project

CITY PROJECT NO. 2017-04

PAYMENT REQUEST : NO. FOUR-FINAL PAYMENT

PAYMENT PERIOD : January 1, 2019 to April 26, 2019

CONTRACTOR: Nielsen Concrete, LLC

PAYMENT AMOUNT: \$2505.76

Approved By:

Tom Kullagj 4/30/19
Department Head Date

Director of Finance Date
Lee A. Mattson 4-30-19
City Manager Date

CONTRACT CONSTRUCTION PAYMENT REQUEST

DATE: April 29, 2019

TO: Mayor & City Council
Lee Mattson-City Manager

PROJECT NAME: 2017 SIDEWALK PROJECT

CITY PROJECT NOS.: 2017-04

PAYMENT REQUEST : NO. FOUR-FINAL PAYMENT

PAYMENT PERIOD : January 1, 2019 to April 26, 2019

CONTRACTOR: NIELSEN CONCRETE, LLC.
365 INDUSTRIAL ST E
KASOTA, MN 56050

CONTRACT

Original Contract sum:	\$ 123,557.25
Change Orders	
Change Order No. One 4-29-19	\$ 1,730.58
 Net change by change orders:	 \$ 1,730.58
Contract Sum to date:	\$ 125,287.83

PAYMENT

Contract Amount to date:	\$ 125,287.83
Change Orders to date:	\$1,730.58
Total completed to date (earned):	\$ 125,287.83
Retainage: 0%	\$ -
Total earned less retainage:	\$ 125,287.83
Less previous payment requests:	\$ 122,782.07
Payment due this request:	\$ 2,505.76
% Contract completed to date:	100%
Amount remaining on contract	\$ -
Total Amount Due	\$ 2,505.76

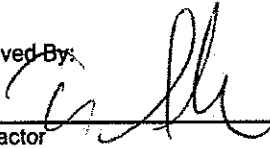
Approved By:  _____
Contractor Date 4/29/19

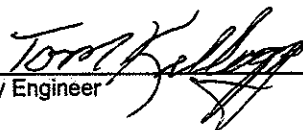
 _____
City Engineer Date 4/30/19

Director of Finance Date

City Manager Date

CHANGE ORDER

CHANGE ORDER NO. ONE

CITY OF WASECA PROJECT NO. 2017-04

DATE: APRIL 29, 2019

PROJECT NAME: 2017 SIDEWALK PROJECT

CONTRACTOR:

NIELSEN CONCRETE, LLC
365 INDUSTRIAL ST E
KASOTA, MN 56050

THE JUSTIFICATION FOR THIS CHANGE ORDER IS:
Contract quantities exceeded estimated quantities.

ITEM	UNIT	QTY.	UNIT PRICE	INCREASE (DECREASE)
Increased Contract Quantities	L.S.	1	\$1,730.58	<u>\$1,730.58</u>
TOTAL CHANGE ORDER NO. ONE				<u>\$1,730.58</u>

ORIGINAL CONTRACT PRICE	\$123,557.25
PREVIOUS CHANGE ORDERS	\$0.00
AMOUNT OF THIS CHANGE ORDER	\$1,730.58
REVISED CONTRACT AMOUNT	\$125,287.83

APPROVED BY:

[Signature] 4/29/19
CONTRACTOR DATE

[Signature] 4/30/19
CITY ENGINEER DATE

DIRECTOR OF FINANCE DATE

CITY MANAGER DATE

Title:	Water Alliance Proposal		
Meeting Date:	May 7, 2019	Agenda Item Number:	7C
Action:	<input type="checkbox"/> MOTION <input type="checkbox"/> REQUESTS/PRESENTATIONS <input checked="" type="checkbox"/> RESOLUTION <input type="checkbox"/> ORDINANCE <input type="checkbox"/> DISCUSSION	Supporting Documents:	Resolution 19-21
Originating Department:	Administration	Presented By:	City Manager
Approved By City Manager: <input checked="" type="checkbox"/>	Proposed Action: Approve Resolution 19-21.		
How does this item pertain to Vision 2030 goals?	The proposed resolution would encourage collaboration between the City, County, and Township to achieve goals of mutual interest. This type of collaboration is specifically called for in the Vision 2030 document.		

BACKGROUND: Representatives of Woodville Township, Waseca County, and the City of Waseca have all expressed informal interest in undertaking joint action to address surface water concerns. The proposed resolution would affirm the City’s interest in working together to address water issues. This joint effort would encompass issues such as Gaiter Lake as well as surface water impacts that are felt further downstream within the watershed.

The City of Waseca would be the first governmental entity to consider this resolution. If the Council supported it, presentations would be made to Waseca County and Woodville Township to secure their support. It is likely that engineering or legal advice would need to be obtained to assist us in understanding the issues we face, our options in dealing with them, and assistance in charting a path forward.

BUDGET IMPACT: Unknown. Dependent upon the number of issues and the need for various consultants to address them.

POLICY QUESTION: Should the City of Waseca commit to undertake cooperative action with Waseca County and Woodville Township to address issues of mutual concern pertaining to surface water?

ALTERNATIVES CONSIDERED: No action, unilateral action, creation of a formal body or Joint Powers Agreement to investigate these issues.

RECOMMENDATION: Staff recommends approval. This would be a first step that would not permanently bind any member to future action.

RESOLUTION NO. 19-21

**A RESOLUTION OF THE WASECA CITY COUNCIL
SUPPORTING JOINT ACTION WITH WASECA COUNTY AND
WOODVILLE TOWNSHIP TO INVESTIGATE AND ADVOCATE
ON SURFACE WATER ISSUES**

WHEREAS, the City of Waseca wishes to better understand the issues surrounding water resource management and how environmental concerns and the protection of private property are provided for by state policy and rulemaking; and,

WHEREAS, the City of Waseca desires to advocate for solutions that are grounded in science and based upon fact-based investigation and research; and,

WHEREAS, the City of Waseca believes in the power of local alliances to bring people together to gather information, learn, dialogue, and identify potential projects with the potential to benefit area residents, regardless of the local jurisdiction in which they live.

NOW THEREFORE BE IT RESOLVED, that the Waseca City Council support joint action with Waseca County and Woodville Township to gather information and develop specific proposals that could form the basis of conversations with local, state, or federal agencies.

BE IT FURTHER RESOLVED, that the Waseca City Council supports joint action and will refrain from undertaking unilateral action on issues that have been identified as areas of joint concern without first informing Waseca County and Woodville Township of its intent to do so.

Adopted this 7th day of May, 2019.

R. D. SRP
MAYOR

ATTEST:

MIKE ANDERSON
ASSISTANT TO THE CITY MANAGER

Title:	Council Applications Discussion		
Meeting Date:	April 16, 2019	Agenda Item Number:	7D
Action:	<input checked="" type="checkbox"/> MOTION <input type="checkbox"/> REQUESTS/PRESENTATIONS <input type="checkbox"/> RESOLUTION <input type="checkbox"/> ORDINANCE <input checked="" type="checkbox"/> DISCUSSION	Supporting Documents:	
Originating Department:	Administration	Presented By:	Administration
Approved By City Manager: <input checked="" type="checkbox"/>	Proposed Action: Discuss the Council Vacancy Applications from eligible residents. Determine if additional process is desired. If Council chooses, they can appoint by making a motion of approval.		
How does this item pertain to Vision 2030 goals?	Good Governance		

BACKGROUND: At the April 2, 2019 the City Council declared a vacancy seat for Ward 1. City staff posted an application for residents to fill out and apply for the vacant seat. According to the City Charter the City Council can appoint an eligible resident to fill this seat through the next general election which will be held in 2020. At that time, this seat will be on the ballot for election to fill the remainder of the term through 2022.

Two residents have submitted applications to fill this vacant seat. They currently reside in the Ward 1 territory and are considered eligible.

Staffs have received two other applications, both living outside of the Ward 1 boundaries and are not considered eligible.

Earlier this evening Council held Interviews of the two applicants.

BUDGET IMPACT: None

POLICY QUESTION: None

ALTERNATIVES CONSIDERED: Extend the application process until Council feels comfortable with the applications and their process.

RECOMMENDATION: Discuss the interviews held for vacant seat earlier this evening. If the Council wishes, they can appoint to fill the vacant seat until the 2020 election. Council can also decide to continue accepting applications. Staff would recommend Council Discussion at this time.

EXHIBIT A

METHOD OF CALCULATING FOOTAGES FOR ASSESSMENTS

In order to have consistency in calculating footages to be used to establish assessments for various municipal projects, the following method shall be used. This is not intended to cover every possible condition, but is intended to provide guidelines for the City Staff to calculate assessments.

1. For purposes of calculating assessments, a parcel of land eighty feet (80') by one hundred and twenty feet (120') is being used as a basis.
2. For corner lots, a credit will be given on each side at the time a project is constructed on either one side or both sides, but only for the side being constructed at the time. The intent of the credit is to recognize the extra burden placed on these parcels, while at the same time providing an equitable recognition of the benefit of extra frontage on a street. The credit given will be one half (1/2) the length of the frontage on each street, but the credit will not exceed forty feet (40') on the short side of the parcel, and will not exceed sixty feet (60') on the long side of the parcel. Double-frontage lots will be assessed using the same method as corner lots. Examples are included below.

(revised Jun 2011 Resol 11-26)

Example #1

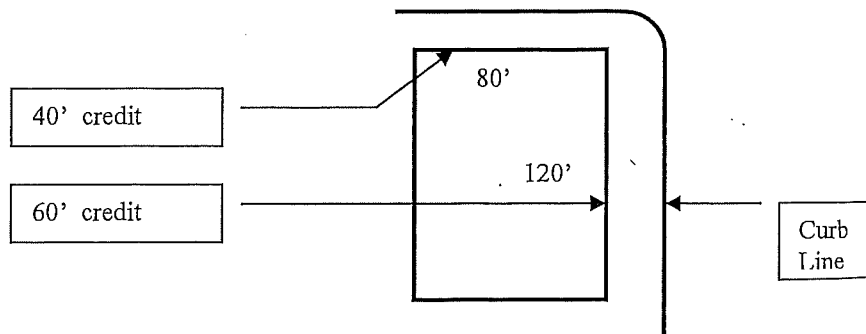

Property would be assessed 60 feet on the 120' side and 40 feet on the 80' side.

Example #2

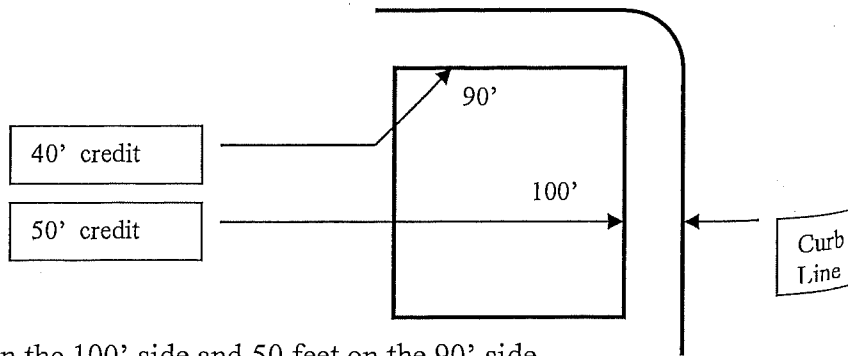

Property would be assessed 50 feet on the 100' side and 50 feet on the 90' side.

Example #3

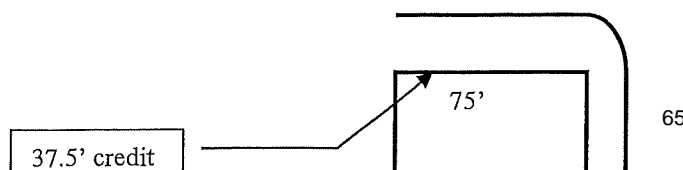

Property would be assessed 37.5 feet on the 75' side and 90 feet on the 150' side.

- 3 For cul-de-sac lots, flag lots and other irregular lots, the assessable footage will be calculated on an adjusted front footage basis, using the lot width at the front building setback line to determine the assessable footage.

(revised Jun 2011 Resol 11-26)

